



- Operating voltage: 36V
- Nominal capacity: 2200 lb (24" of load center)
- Lifting height of up to 211.8"
- Curve speed control (CSC)
- Electric steering
- AC traction motor and pump



TWO RIDER SET-UPS PROPOSED:

**FORWARD
FACING**



**SIDE
FACING**



MIP 10

MIP 10 S

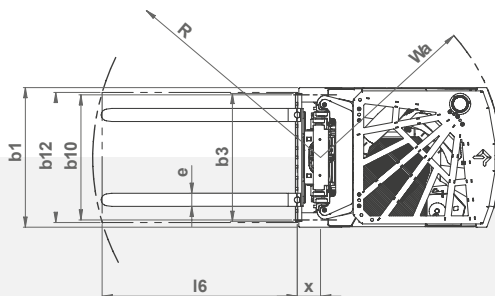
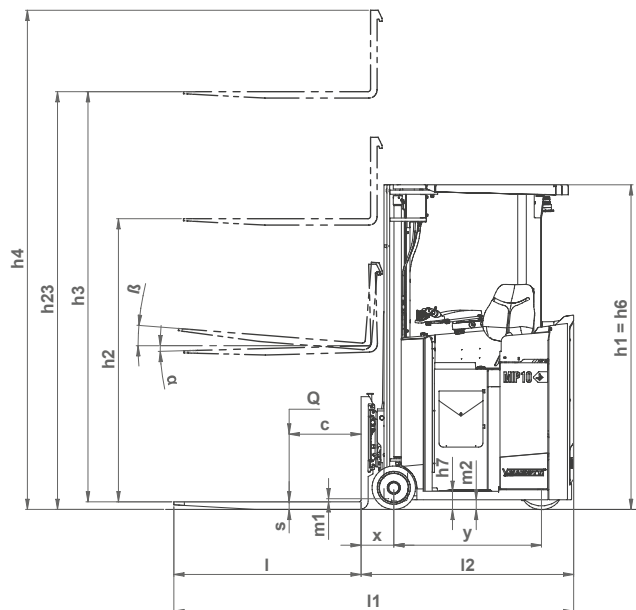
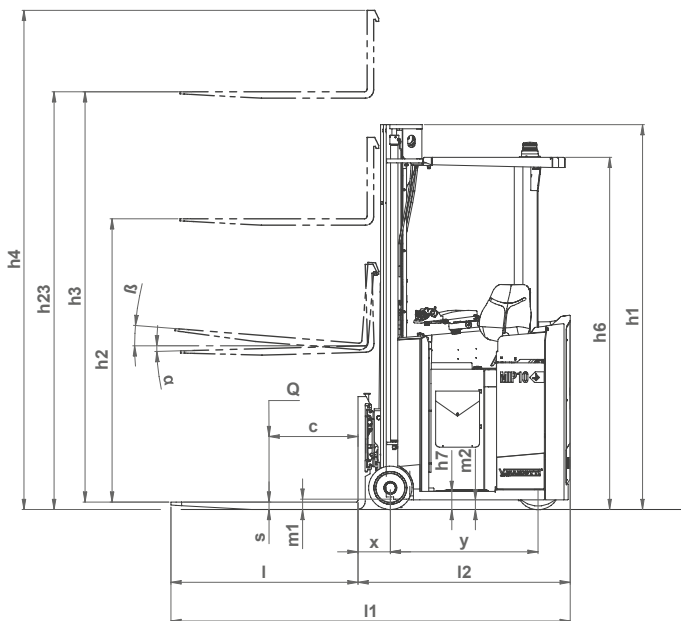

Illustrations and technical specifications are indicative only.
The manufacturer reserves the right to make changes without notice.

	1.1 Manufacturer			V.MARIOTTI S.r.l.			V.MARIOTTI S.r.l.			
	CHARACTERISTICS	1.2	Model		MIP 10			MIP 10 S		
		Type of mast		Simplex	Duplex	Triplex	Simplex	Duplex	Triplex	
1.3		Type of drive		Electric			Electric			
1.4		Operator type		Stand-up			Stand-up			
1.5		Load capacity/rated load	Q	lb	2200			2200		
1.6		Load centre distance	c	in	24			24		
1.8		Load distance	x	in	5.6 - [7.9]▲			5.6 - [7.9]▲		
1.9		Wheel base min / max (adjustable)	y	in	35.7			35.7		
WEIGHTS		2.1	Net weight incl. battery (see row 6.5)		4850 □	4960 □	5159 □	4806 □	4872 □	5071 □
	2.2	Axle load, with load, front / rear		5930 / 1124	6041 / 1124	6283 / 1080	5864 / 1146	5930 / 1146	6195 / 1080	
	2.3	Axle load, without load, front / rear		1874 / 2976	1962 / 2998	2116 / 3042	1830 / 2976	1896 / 2976	2072 / 2998	
WHEELS	3.1	Tyres		Polyurethane			Polyurethane			
	3.2	Tyre size front		10.5x3.5x8			10.5x3.5x8			
	3.3	Tyre size rear		10.5x4.7x8			10.5x4.7x8			
	3.5	Wheels, number front/rear (∅ = driven wheels)		2/1∅			2/1∅			
	3.6	Track width, front	b ₁₀	in	30.3			30.3		
	DIMENSIONS	4.1	Tilt of fork carriage forward/backward		[2° / 4°]▲			[2° / 4°]▲		
4.2		Closed mast height		93.1			78.6			
4.3		Free lift	h ₂	in	72.4 - [70.1]▲	72.4 - [70.1]▲	72.4 - [70.1]▲	58.3 - [55.5]▲	58.3 - [55.5]▲	58.3 - [55.5]▲
4.4		forks lifting	h ₃	in	70.9 - [67.9]▲	140.2 - [137.6]▲	210.2 - [207.3]▲	56.7 - [53.3]▲	115.7 - [112.4]▲	174.7 - [171.5]▲
		Lifting height	h ₂₃	in	72.4 - [69.7]▲	141.7 - [139.4]▲	211.8 - [209.1]▲	58.3 - [55.1]▲	117.3 - [114.2]▲	176.4 - [173.2]▲
4.5		Height mast extended	h ₄	in	93.1 - [96.5]▲	162.8 - [165.8]▲	232.5 - [235.4]▲	78.7 - [82]▲	137.6 - [140.7]▲	196.7 - [199.8]▲
4.7		Height of overhead guard	h ₆	in	85.2			78.6		
4.8		Stand height	h ₇	in	4.3			4.3		
4.19		Overall length	l ₁	in	94.4 [96.7]▲			94.4 [96.7]▲		
4.20		Length including back of forks	l ₂	in	49.1 [51.4]▲			49.1 [51.4]▲		
4.21		Overall width	b ₁	in	33.8			33.8		
4.22		Fork dimensions	s/e/l	in	1.6x3.1x45.3 - [1.8x3.1x45.3]▲			1.6x3.1x45.3 - [1.8x3.1x45.3]▲		
4.23		Forks carriage ISO 2328, Class/form A, B			ISO II/A - [ISO II Special]▲			ISO II/A - [ISO II Special]▲		
4.24		Forks carriage width	b ₃	in	26.4 [30.9]▲			26.4 [30.9]▲		
4.31		Floor clearance with load under mast	m ₁	in	2.1			2.1		
4.32		Floor clearance centre wheelbase	m ₂	in	2.3			2.3		
4.34		Right Angle Stack (for a 40" wide by 48" long pallet load)	Ras	in	101 [103]▲			101 [103]▲		
4.35	Turning radius	W _a	in	43.7			43.7			
PERFORMANCE	5.1	Driving speed with/without load		4.9 / 5			4.9 / 5			
	5.2	Lift speed with/without load		55.1 / 74.8			55.1 / 74.8			
	5.3	Lowering speed with/without load		68.9 / 51.2			68.9 / 51.2			
	5.7	Gradeability, with/without load		5 / 6			5 / 6			
	5.8	Max Gradeability, with/without load		5 / 6			5 / 6			
	5.10	Service brake		Electromagnetic braking system			Electromagnetic braking system			
ELECTRIC SYSTEM	6.1	Drive motor rating S2 60 min.		2.2			2.2			
	6.2	Lift motor rating at S3 20%		6.5			6.5			
	6.4	Battery voltage/nominal capacity K5		36/310			36/310			
	6.5	Battery weight (±5%)		860			860			
OTHER	8.1	Type of drive control		AC MOSFET			AC MOSFET			
	8.2	working pressure for attachments		2610			2610			
	8.4	Sound pressure level at operator's ear		-			-			

▲ [With optional fork tilt and/or side shift]

□ Weight may vary depending on the optionals chosen

Non-standard tires, different masts, optional equipment, etc. may result in different values.
Right Angle Stack and Equal Intersecting Aisle dimensions (provided with a 48" long and 40" wide pallet load) allowing zero clearance.
Data showed are not binding and are liable to variations. The constructor reserves the right of changes without notice.



fairchildequipment.com
(844) 432-4724



MariottiUSA Inc.
www.mariottiusa.com
Call (877) 698-9777