



MATERIAL HANDLING PRODUCTS



One Million Square Feet
of Production Facilities

DREXEL



R60i5

ANYTHING ELSE is a **WASTE** of **SPACE!**

STANDARD FEATURES

- 6,000 lb. (2722kg) Capacity at 24" (610mm) Load Center
- Four-Wheel Design, Dual Independently Driven Front Wheels
- Solid, Pneumatic-Style Drive and Steer Tires
- LPG Engine, Kubota 2.5L Tier III and LPG Fuel System (Tank Not Included)
- Integrated Computer Controlled Hydrostatic Drive
- Hydrostatic Power Steering with Tilt Steering Wheel
- Single Joystick Hydraulic Control
- 23" (584mm) of Shift Includes 2" (51mm) of Reach
- 40" (1,016mm) Forks with Standard Bottom Taper and Class III Carriage and Long Load Handling Package
- Dash Display Contains: Engine Coolant Temperature Gauge, Hour Meter, Clock, Warning Icons and Display Function Buttons
- 91" (2,311mm) High Overhead Guard
- 42" (1,067mm) High Load Backrest, 48" (1,219mm) Wide Fork Carriage
- Neutral Start, Anti Restart, Operator Presence Seat Switch
- Adjustable Steering Column, Key Switch, Rear View Mirror, Horn and Seat Belt
- Comfortable Seated Operation with Vinyl / Cloth Suspension Seat
- Mast Tilt of 3° Forward and 4° Backward

OPTIONAL FEATURES

- Non-Standard Fork Lengths
- LED Headlights, Flashing Light and Rear Safety Lights
- Integral Fork Positioner
- Single Auxiliary Hydraulics
- Cloth Seat
- Fire Extinguisher
- Steel / Glass Cab with Wipers, Heater and Defroster
- UL 583 LPS Safety Rating, UL Listed

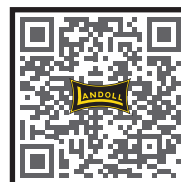

Scan the QR Code
to Learn More!



R60i5

4-Wheel Heavy Capacity LP Gas Side Loader VNA Truck

TECHNICAL DATA

MODEL			
Capacity	24" (610mm) Load Center	lbs/kg	6,000 / 2,722
Engine Displacement	LPG	liter	2.5L
Truck Weight	with 3 stage 240" (6096mm)	lbs/kg	17,500 / 7,955
Travel Speed	Loaded	mph/kph	8 / 12.9
	Unloaded	mph/kph	8 / 12.9
Lift Speed	Loaded	fpm/mpm	85 / 26
	Unloaded	fpm/mpm	87 / 27
Lowering Speed	Loaded	fpm/mpm	60 / 18
	Unloaded	fpm/mpm	50 / 15
Mast Tilt	Forward / Backward	deg	3 / 4
Lost Load Center	E with Triple Mast	in/mm	31 / 790
Wheelbase	F	in/mm	77 / 1,940
Rear Overhang	G	in/mm	13 / 340
Overall Length to Face of Forks	H with Triple Mast	in/mm	122 / 3,100
Underclearance - Straddle	I	in/mm	6 / 152.4
Seat Clearance	J	in/mm	37 / 930
Overhead Guard Height	K	in/mm	91 / 2,310
Rear Frame Width	L	in/mm	52 / 1,320
Fork Carriage Width	M	in/mm	48 / 1,219
Mast Shift	N	in/mm	23 / 584
Rear Ground Clearance	P	deg	23°
Center Ground Clearance	Q	deg	16°
Side Deck Width	R	in/mm	21 / 530
Load Backrest Height	S	in/mm	42 / 1,070
Turning Radius	T	in/mm	106 / 2,690
Overall Width	U	in/mm	54 / 1,370
Side Deck Height	V	in/mm	52 / 1,320
Fork Size (Standard) ITA CLASS III		in/cm	1.75 x 5 x 40 / 4.5 x 13 x 102
Gradeability	Loaded	%	15
	Unloaded	%	15
Wheel Sizes	Front (Solid Pneumatic in/cm Dia x Face)	in/cm	28 x 12.5 / 71 x 31.75
	Rear (Solid Pneumatic Dia x Face)	in/cm	22.7 x 6.5 / 58 x 16.5
Hydrostatic Transmission	Forward / Reverse		Single Speed

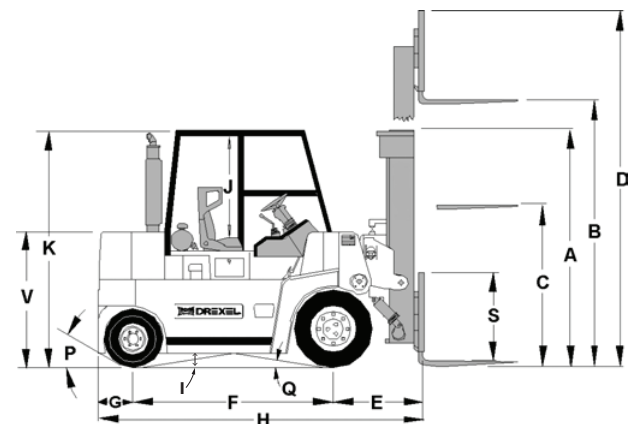
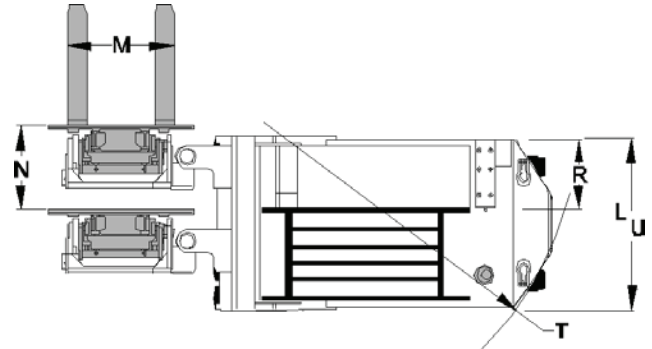

MAST DIMENSIONS

MAX FORK HEIGHT (B)		COLLAPSED HEIGHT (A)		FREE LIFT HEIGHT (C)		MAX OVERALL HEIGHT (D)	
In	M	In	M	In	M	In	M
Triple (3-Stage)							
181	4.60	89	2.26	55	1.40	223	5.66
187	4.75	91	2.31	57	1.45	229	5.82
196	4.98	95	2.41	61	1.55	238	6.05
215	5.46	103	2.62	71	1.80	257	6.53
240	6.10	113	2.87	79	2.01	282	7.16

Above Dimensions are Based on a 9" (23cm) Mast Underclearance

AISLE DIMENSIONS

LOAD DEPTH X WIDTH	MINIMUM CLEAR AISLE
40" x 48" (1,000 x 1,200mm)	68" (1,727mm)
48" x 40" (1,200 x 1,000mm)	72" (1,829mm)
Minimum Clear Transfer Aisle with Load	176" (447cm)



Landoll continuously improves products. We reserve the right to make any changes in illustrations, specifications, equipment, and prices without prior notice and without changes on previous models.

QUALITY IS OUR FIRST PRIORITY



Exceptional Customer Support, Parts and Service

Landoll is committed to total customer satisfaction by providing products and services of the highest quality. Aftermarket parts and service is available world-wide through our factory trained dealer network and Landoll's service support department. Our 75,000 square foot Parts Distribution Center ensures quick and accurate delivery of parts to keep your equipment up and running. Experience for yourself the reason that Landoll Material Handling Products are #1 in customer retention.

Proven Solutions for Storage & Specialty Handling Applications

Family owned and operated since 1963, we make quality our first priority. Our goal is to provide the best solution for your material handling needs. Bendi articulating, Drexel SwingMast® Narrow Aisle and Very Narrow Aisle forklifts provide that solution. Through increased utilization of space, improved productivity, greater flexibility and maximized efficiency. We stay on the edge of modern and innovative technology. We know that for our customers "Quality is Always a Bargain".

FORKLIFT AISLE COMPARISON

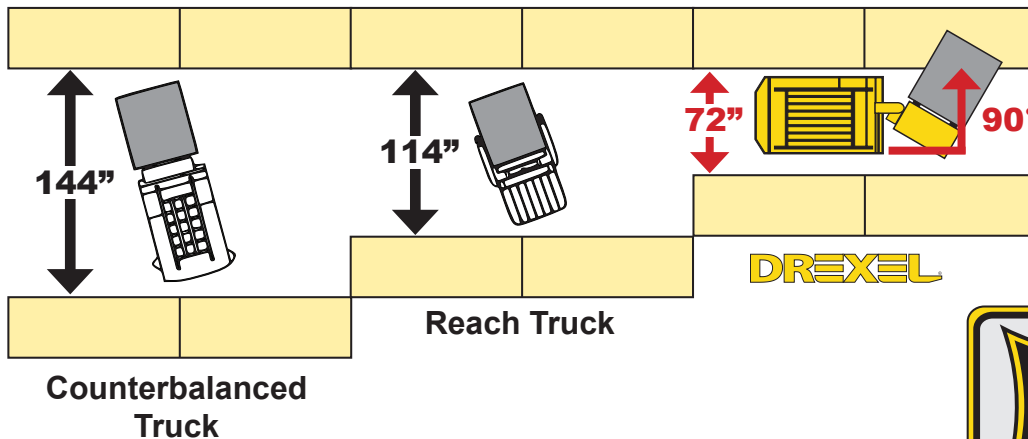

Drexel VNA Forklifts save on warehouse space by **35%** compared to a reach truck and by **50%** compared to a counterbalanced truck.



MATERIAL HANDLING PRODUCTS

landoll.com/mhp

fairchildequipment.com (844) 432-4724



Landoll continuously improves products. We reserve the right to make any changes in illustrations, specifications, equipment, and prices without prior notice and without changes on previous models.

R6015-0224