



# MATERIAL HANDLING PRODUCTS



One Million Square Feet  
of Production Facilities



# Bendi®

## B40i5

**ANYTHING ELSE** is a **WASTE** of **SPACE!**

# Bendi®



## STANDARD FEATURES

- 4,000 lb. (1,814kg) Capacity at 24" (610mm) Load Center
- Tier III Certified, LP Gas, 2.5L, Kubota Industrial Engine
- Gear Driven Valve Train - No Belts or Chains
- CAN-Bus Electronics for Integrated Control of Drive, Lift and Engine
- Simplified Maintenance, Diagnostics and Calibration through Dash Display
- Dash Display with Hour Meter, Fuel Gauge and Engine Monitoring
- Via-Sonic Fuel Level Sensor with 99.5% Accuracy
- Heavy Duty Dual Rear Wheel Hydraulic Motors
- Automatic Hydrostatic Braking and Foot Activated Hydraulic Parking Brake
- Lift Heights to 360" (9.14M)
- 78" (1.98M) Stacking Aisle with 48" (1,219mm) Long Load
- High Visibility 3-Stage or 4-Stage Mast
- Integral 11.2" (285mm) Stroke Sideshifter and 36" (914mm) High Load Backrest
- Indoor / Outdoor Capability
- Articulated 42" (1,067mm) Wide Floating Front Axle
- Large Diameter Smooth Rubber Drive Tires
- Polyurethane Load Tires
- 180° Front-End "DuraSteer" Articulation / Steering Assembly with Extended Warranty
- Comfortable Seated Operation with All Truck Controls within Easy Reach
- Adjustable Vinyl Suspension Swivel Seat
- Armrest and Adjustable Steering Column, Key Switch, Horn and Seat Belt
- Hydraulic Power Steering
- 4-Post Heavy-Duty Adjustable Overhead Guard, Meets ANSI B56.1
- Safety Deadman Seat Switch
- Heavy Duty Unitized Robotic Welded Chassis Design
- Provisions for RF Terminals Provided
- Accepts Class II Attachments
- Easily Accessible Components for Low Cost Maintenance

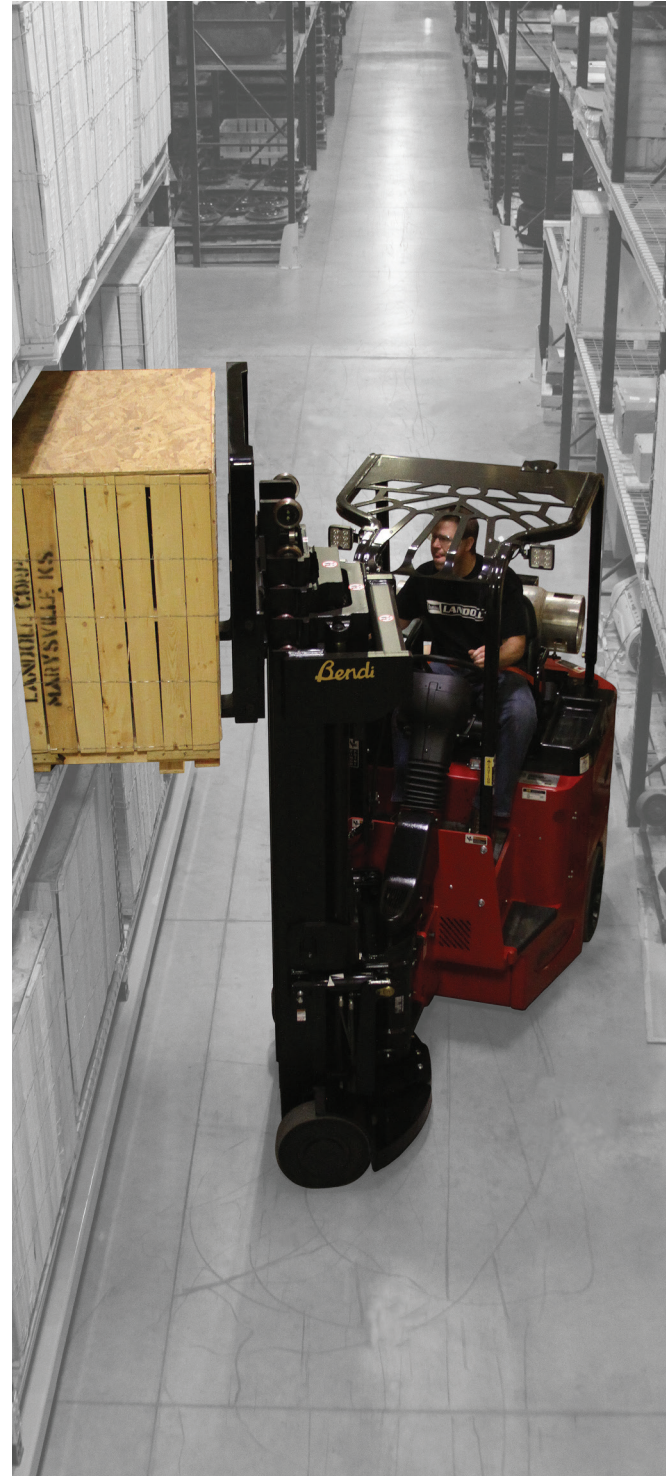

Scan the QR Code  
to Learn More!





# B40i5

## 4-Wheel Heavy Capacity LP Gas Engine Powered Multi-Purpose Articulated Forklift

### TECHNICAL DATA

MODEL			B40i5
Capacity	at 24" (600mm) Load Center	lbs/kg	4,000 / 1,814
Truck Weight	with Battery	lbs/kg	13,700 / 6,214
Travel Speed	Loaded	mph/kph	8 / 13
	Unloaded	mph/kph	8 / 13
Lift Speed	Loaded	fpm/mpm	90 / 27.4
	Unloaded	fpm/mpm	100 / 30.5
Lowering Speed	Loaded	fpm/mpm	100 / 30.5
	Unloaded	fpm/mpm	90 / 27.4
Mast Tilt	Fwd / Back - Up to 293" (7.44M)	deg	3 / 3
	Fwd / Back - 294" (7.45M)	deg	1 / 2
	to 360" (9.14M)	deg	1 / 2
HP Rating	LP Gas Engine at 2,600 RPM	HP	61.7
Lost Load Center	E	in/cm	12 / 30.5
Wheelbase	F	in/cm	69 / 175.25
Rear Overhang	G	in/cm	28 / 71
Overall Length to Fork Face	H	in/cm	109 / 277
Axle Underclearance	I	in/cm	3.7 / 9.4
Operator Floor Height	J	in/cm	33.5 / 85
Overhead Guard Height	K	in/cm	87 / 221
Overhead Guard Width	L	in/cm	40 / 101.5
Overall Width	M	in/cm	49 / 124.5
Fork Carriage Width	N	in/cm	37 / 94
Fork Length	O	in/cm	40 / 101.5
Out to Out Fork Spread	P Minimum / Maximum	in/cm	9.4-37 / 24-94
Intermediate Step Height	Q	in/cm	19 / 48
Right Angle Stacking Aisle	with 48"L x 40"W (1200mm x 1000mm) Load	in/cm	78 / 198
Intersecting Aisle		in/cm	114 / 289
Gradeability	Loaded / Unloaded	%	15 / 15
Wheel Sizes	Front 2 Each Poly-Dia. x Face	in/cm	14x5 / 36x13
	Rear 2 Each Rubber-Dia. x Face	in/cm	18x7x12 / 46x18x30
Straddle Clearance		in/cm	2.5 / 6.4

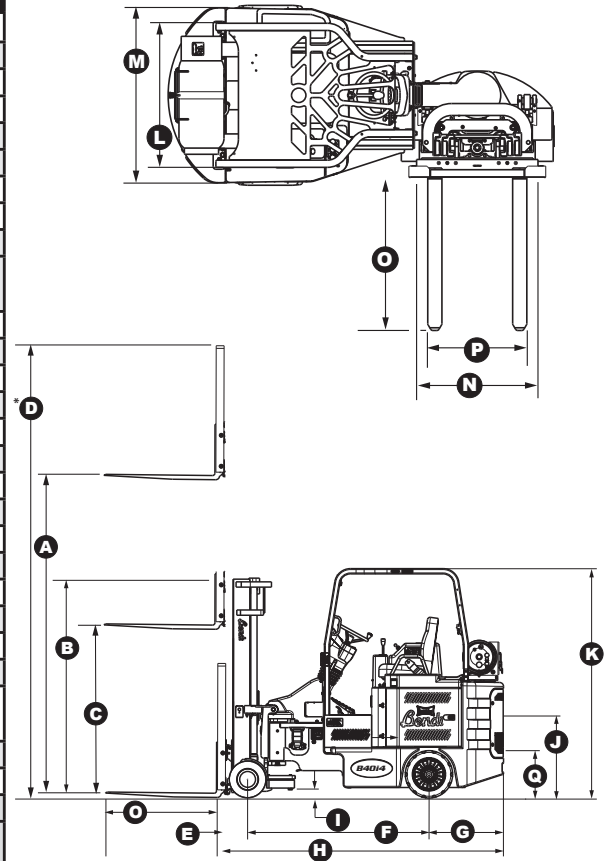

### MAST DIMENSIONS

LIFT HEIGHT (A)		LOWERED HEIGHT (B)		*FREE LIFT (C)		**OVERALL HEIGHT (D)	
In	M	In	M	In	M	In	M
Triple (3 Stage) Mast							
188	4.78	83	2.11	47	1.19	224	5.69
198	5.03	87	2.21	51	1.30	234	5.94
216	5.49	95	2.41	59	1.50	252	6.40
224	5.69	98	2.49	62	1.57	260	6.60
240	6.10	106	2.69	70	1.78	276	7.01
258	6.55	115	2.92	79	2.01	294	7.47
272	6.91	121	3.07	85	2.16	308	7.82
294	7.47	128	3.25	92	2.34	330	8.38
312	7.92	132	3.35	96	2.44	348	8.84
322	8.18	137	3.48	101	2.57	358	9.09
360	9.14	156	3.96	120	3.05	396	10.06

LIFT HEIGHT (A)		LOWERED HEIGHT (B)		*FREE LIFT (C)		**OVERALL HEIGHT (D)	
In	M	In	M	In	M	In	M
Quad (4 Stage) Mast							
250	6.35	87	2.21	51	1.30	286	7.26
258	6.55	89	2.26	53	1.35	294	7.47
276	7.01	95	2.41	59	1.50	312	7.92
294	7.47	101	2.57	65	1.65	330	8.38
312	7.92	107	2.72	71	1.80	348	8.84
* Free Lift Based on 36" (914mm) High Load Backrest							
** Overall Height Based on 36" (914mm) High Load Backrest							

### AISLE DIMENSIONS

LOAD DEPTH X WIDTH	MINIMUM CLEAR AISLE
40" x 48" (1,000 x 1,200 mm)	72" (1,828 mm)
48" x 40" (1,200 x 1,000 mm)	78" (1,981 mm)
Transfer or End Aisle	114" (2,895 mm)

Landoll continuously improves products. We reserve the right to make any changes in illustrations, specifications, equipment, and prices without prior notice and without changes on previous models.

# QUALITY IS OUR FIRST PRIORITY



## Exceptional Customer Support, Parts and Service

Landoll is committed to total customer satisfaction by providing products and services of the highest quality. Aftermarket parts and service is available world-wide through our factory trained dealer network and Landoll's service support department. Our 75,000 square foot Parts Distribution Center ensures quick and accurate delivery of parts to keep your equipment up and running. Experience for yourself the reason that Landoll Material Handling Products are #1 in customer retention.

## Proven Solutions for Storage & Specialty Handling Applications

Family owned and operated since 1963, we make quality our first priority. Our goal is to provide the best solution for your material handling needs. Bendi articulating, Drexel SwingMast® Narrow Aisle and Very Narrow Aisle forklifts provide that solution. Through increased utilization of space, improved productivity, greater flexibility and maximized efficiency. We stay on the edge of modern and innovative technology. We know that for our customers "Quality is Always a Bargain".

## FORKLIFT AISLE COMPARISON

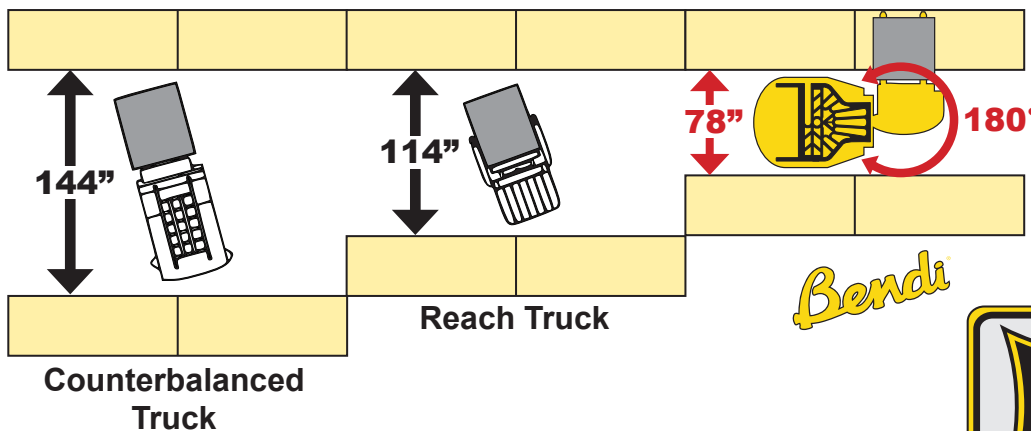

**Bendi Narrow Aisle Forklifts** save on warehouse space by **20%** compared to a reach truck and by **36%** compared to a counterbalanced truck.



## MATERIAL HANDLING PRODUCTS

[landoll.com/mhp](http://landoll.com/mhp)

[fairchildequipment.com](http://fairchildequipment.com) (844) 432-4724



Landoll continuously improves products. We reserve the right to make any changes in illustrations, specifications, equipment, and prices without prior notice and without changes on previous models.

B40i5-0224