



MATERIAL HANDLING PRODUCTS



One Million Square Feet
of Production Facilities

Bendi®



B30AC/B40AC



B55AC

ANYTHING ELSE is a **WASTE** of **SPACE!**

Bendi®

The Landoll Bendi B30AC and B40AC are 4-wheel, articulating, AC powered, narrow aisle forklifts maximizing cube utilization while providing front loader versatility. Maximum space utilization, increased productivity, operator comfort and safety are the primary benefits.

STANDARD FEATURES

- 3,000 lb. (1,361kg) and 4,000 lb. (1,814kg) Capacity at 24" (610mm) Load Center
- Lift Heights to 374" (9.5 M)
- 78" (1.98M) Stacking Aisle with 48" (1,200mm) Long Load
- High Visibility 3-Stage or 4-Stage Mast
- Integral 11.2" (285mm) Stroke Side Shifter and 36" (914mm) High Load Backrest
- Dual Inside / Outside Capability
- Articulated 42" (1,067mm) Wide Floating Front Axle
- Large Diameter Smooth Rubber Drive Tires
- Polyurethane Smooth Load Tires
- 180° Front-End DuraSteer™ Articulation / Steering Assembly with 5-Year Warranty
- Heavy Duty Dual Rear Wheel Planetary Drives
- AC Traction and Hydraulic Controllers with Lift Interrupt
- UL583, Type E Electrical Rating, UL Listed
- Creep Speed Mode Select in Switch
- Powerful AC Drive and Hydraulic Motors
- Comfortable Seated Operation with All Truck Controls in Easy Reach
- Full Diagnostic Interactive Color Display with Battery Discharge Indicator and Hour Meter
- Adjustable Cloth Suspension Seat
- Armrest, Adjustable Steering Column, Key Switch, Horn and Seat Belt
- Hydraulic Power Steering
- 4-Post Heavy-Duty Adjustable Overhead Guard, Meets ANSI B56.1
- Safety Deadman Seat Switch
- Heavy Duty Unitized Robotic Welded Chassis Design
- Provisions for RF Terminals Provided
- Accepts Class II Attachments
- Easily Accessible Components for Low Cost Maintenance



**Dash Display with Full Diagnostics
Battery Discharge Indicator and Hour Meter**



**DuraSteer™ Front Wheel Steering
*Patented**

B30/40AC

4-Wheel Heavy Capacity

Electric Multi-Purpose Narrow Aisle Articulating Forklift Truck

OPTIONAL FEATURES

- Non-Standard Fork Lengths
- LED Headlights, Flashing Light and Rear Safety Lights
- Integral Side Shifting Fork Positioner
- Auxiliary Hydraulics
- Non-Marking Tires
- UL-583, Type EE Electrical Rating, UL Listed

- Vinyl Seat
- Slide-Out Sideways Battery Tray
- Fire Extinguisher
- Lazer Fork Height Indicator
- Camera with Operator Compartment Monitor
- Cold Storage Option for Freezer Operation to -22°F (-30°C)





TECHNICAL DATA

MODEL			B30AC	B40AC
Capacity		at 24" (600mm) Load Center	lbs/kg	3,000 / 1,361
Weight		with Battery	lbs/kg	13,630 / 6,182
Travel Speed		Loaded	mph/kph	6.5 / 10.5
		Unloaded	mph/kph	7 / 11.3
Lift Speed		Loaded	fpm/mpm	90 / 27.4
		Unloaded	fpm/mpm	110 / 33.5
Lowering Speed		Loaded	fpm/mpm	100 / 30.4
		Unloaded	fpm/mpm	90 / 27.4
Mast Tilt		Fwd / Back - Up to 293" (7.44M)	deg	3 / 3
		Fwd / Back - 294" (7.46M) and Higher	deg	1 / 2
Lost Load Center	E		in/mm	12 / 305
Wheelbase	F		in/mm	63 / 1,600
Rear Overhang	G		in/mm	25 / 635
Overall Length Fork to Face	H	Mast Vertical	in/mm	100 / 2,540
Underclearance	I	Under Mast	in/mm	3 / 76
Operator Floor Height	J		in/mm	31 / 787
Overhead Guard Height	K		in/mm	89 / 2,261
Overhead Guard Width	L		in/mm	40 / 1,016
Overall Width	M		in/mm	45 / 1,143
Fork Carriage Width	N		in/mm	41 / 1,041
Fork Length	O		in/mm	40 / 1,016
Out to Out Fork Spread	P	Minimum / Maximum	in/mm	9.4-39.5 / 239-1,003
Battery Compartment Height	Q	Floor to Top of Battery Tray	in/mm	19 / 483
Right Angle Stacking Aisle		with 48"L x 40"W (1,200mm x 1,000mm) Load	in/mm	78 / 1,981
Intersecting Aisle		with 48"L x 40"W (1,200mm x 1,000mm) Load	in/mm	108 / 2,743
Gradeability		Loaded / Unloaded	%	15
Hydraulic Motor Rating		Continuous Duty Rating	type/kWh	12
Traction Motor Rating		Continuous Duty Rating	type/kWh	5.1 Ea / 10.2 Total
Traction Control Type		Induction		AC
Hydraulic Control Type		Induction		AC
Wheel Sizes		Front (2 Each) Smooth Poly-Dia x Face	in/mm	14x5 / 356x127
		Rear (2 Each) Smooth Rubber-Dia x Face	in/mm	18x7 / 457x178



Loading / Unloading

The specifications contained in this spec sheet are subject to change at any time without notice. Actual dimensions and performance data given herein may vary due to manufacturing tolerances.

Landoll continuously improves products. We reserve the right to make any changes in illustrations, specifications, equipment, and prices without prior notice and without changes on previous models.

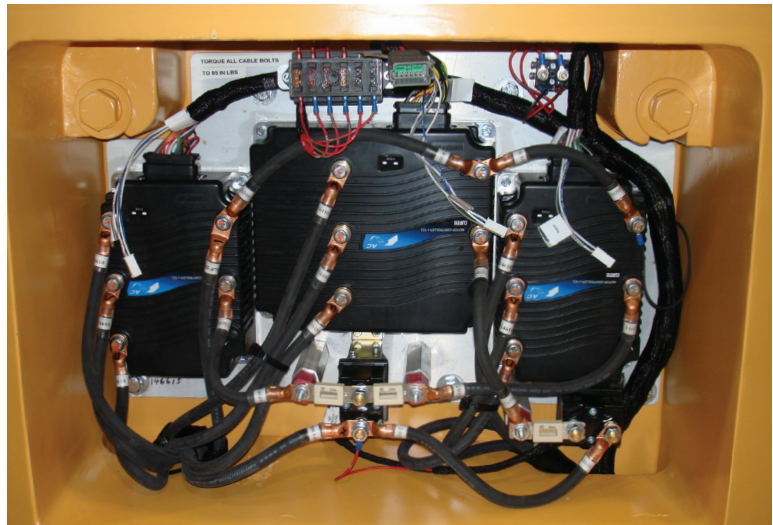

**Rear Controller Compartment
and Counterweight**

B30/40AC

4-Wheel Heavy Capacity Electric Multi-Purpose Narrow Aisle Articulating Forklift Truck

aisle dimensions

LOAD DEPTH X WIDTH	MINIMUM CLEAR AISLE
40" x 48" (1,000 x 1,200mm)	70" (1,778mm)
48" x 40" (1,200 x 1,000mm)	78" (1,981mm)

Mast Dimensions

LIFT HEIGHT (A)		LOWERED HEIGHT (B)		FREE LIFT (C)		OVERALL HEIGHT (D)	
Inches	Meters	Inches	Meters	Inches	Meters	Inches	Meters
Triple (3-Stage) Mast B30AC							
188	4.78	83	2.11	47	1.19	224	5.69
198	5.03	87	2.21	51	1.30	234	5.94
216	5.49	95	2.41	59	1.50	252	6.40
223	5.66	98	2.49	62	1.57	259	6.58
242	6.15	107	2.72	71	1.80	278	7.06
258	6.55	115	2.92	79	2.01	294	7.47
272	6.91	121	3.07	85	2.16	308	7.82
Triple (3-Stage) Mast B40AC							
188	4.78	83	2.11	47	1.19	224	5.69
198	5.03	87	2.21	51	1.30	234	5.94
216	5.49	95	2.41	59	1.50	252	6.40
223	5.66	98	2.49	62	1.57	259	6.58
242	6.15	107	2.72	71	1.80	278	7.06
258	6.55	115	2.92	79	2.01	294	7.47
272	6.91	121	3.07	85	2.16	308	7.82
296*	7.52	129	3.28	93	2.36	332	8.43
312*	7.92	132	3.35	96	2.44	348	8.84
323*	8.20	138	3.51	102	2.59	359	9.12
360*	9.14	156	3.96	120	3.05	396	10.06
374*	9.50	167	4.24	131	3.33	410	10.40
Free Lift Based on 36" (914mm) High Load Backrest							
Overall Height Based on 36" (914mm) High Load Backrest							
Quad (4-Stage) Mast B30AC and B40AC							
250	6.35	87	2.21	51	1.30	286	7.26
258	6.55	89	2.26	53	1.35	294	7.47
276	7.01	95	2.41	59	1.50	312	7.92
294*	7.47	101	2.57	65	1.65	330	8.38
312*	7.92	107	2.72	71	1.80	348	8.84
Quad (4-Stage) Mast B40AC							
336*	8.53	117	2.97	81	2.06	372	9.45
360*	9.14	126	3.20	90	2.29	396	10.06
374*	9.50	130	3.30	94	2.39	410	10.41

* Tilt Restricted to 1° Forward and 2° Backward

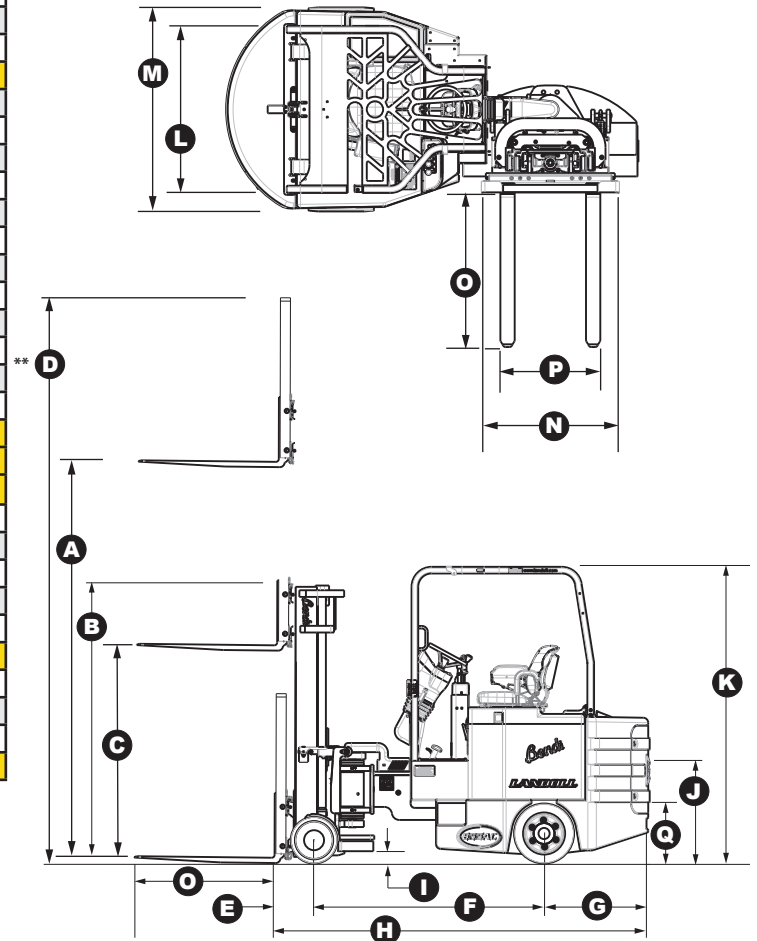

Scan the QR Code to Learn More!

RECOMMENDED BATTERIES

BATTERY FOR B30AC - MINIMUM BATTERY WEIGHT IS 2,550 LBS. (1,159KG) - MAXIMUM WEIGHT IS 3,100 LBS. (1,409KG)

Battery Designation: 24-85-17, 48 Volt, 680 AHC, Nominal Size 27" x 38.5" x 22.625" (69 x 98 x 58cm)

Standard Truck Battery Compartment Size: 27.5" x 38.75" x 23" (70 x 98 x 58cm)

Leads are at Position A, 12" (31cm) Long, with SB 350 Amp Blue Connector

BATTERY FOR B40AC - MINIMUM BATTERY WEIGHT IS 2,600 LBS. (1,181KG) - MAXIMUM WEIGHT IS 3,100 LBS. (1,409KG)

Battery Designation: 24-85-19, 48 Volt, 765 AHC, Nominal Size 25.9375" x 44.5625" x 22.625" (66 x 113 x 58cm)

Standard Truck Compartment Size: 26" x 44.75" x 23" (66 x 114 x 58cm)

Leads are at Position A, 12" (304.8mm) Long, with SB 350 Amp Blue Connector

Bendi®

STANDARD FEATURES

- 5,500 lb. (2,495kg) Capacity
- Lift Heights to 360" (9.14M)
- 84" (2.13M) Stacking Aisle with 48" (1,200mm) Long Load
- High Visibility 3-Stage or 4-Stage Mast
- Integral 11.2" (285mm) Stroke Side Shifter and 36" (914mm) High Load Backrest
- Dual Inside / Outside Capability
- Articulated Floating Front Axle, 48" (1,219mm) Wide
- Large Diameter Smooth Rubber Drive Tires
- Polyurethane Load Tires
- 180° Front-End DuraSteer™ Articulation Steering Assembly with 5-Year Warranty
- Heavy Duty Dual Rear Wheel Planetary Drives
- AC Traction and Hydraulic Controllers, with Lift Interrupt
- Powerful AC Drive and Hydraulic Motors
- Comfortable Seated Operation with All Truck Controls in Easy Reach
- Full Diagnostic Interactive Color Display with Battery Discharge Indicator and Hour Meter
- Adjustable Cloth Suspension Swivel Seat
- Armrest, Adjustable Steering Column, Key Switch, Horn and Seat Belt
- Hydraulic Power Steering
- 4-Post Heavy-Duty Overhead Guard, Meets ANSI B56.1
- Safety Deadman Seat Switch
- Heavy Duty Unitized Robotic Welded Chassis Design
- Provisions for RF Terminals Provided
- Accepts Class II Attachments
- Easily Accessible Components for Low Cost Maintenance
- UL 583, Type E Electrical Rating, UL Listed
- Creep Speed Mode Selection Switch



OPTIONAL FEATURES

- Non-Standard Fork Lengths
- LED Headlights, Flashing Light and Rear Safety Lights
- Integral Side Shifting Fork Positioner
- Auxiliary Hydraulics
- Non-Marking Tires
- UL 583, Type EE Electrical Rating, UL Listed
- Vinyl Seat
- Slide-Out Battery Tray
- Fire Extinguisher
- Lazer Fork Height Indicator
- Camera with Operator Compartment Monitor
- Capable of Freezer Operation to -22°F (-30°C)



Scan the QR Code
to Learn More!

B55AC

4-Wheel Heavy Capacity Electric Multi-Purpose Narrow Aisle Articulated Forklift Truck

TECHNICAL DATA

MODEL			B55AC
Capacity		at 24" (600mm) Load Center	lbs/kg 5,500 / 2,495
Weight		with Battery	lbs/kg 16,950 / 7,705
Travel Speed		Loaded	mph/kph 6.5 / 10.5
		Unloaded	mph/kph 7 / 11.3
Lift Speed		Loaded	fpm/mpm 90 / 27.4
		Unloaded	fpm/mpm 110 / 33.4
Lowering Speed		Loaded	fpm/mpm 100 / 30.5
		Unloaded	fpm/mpm 90 / 27.4
Mast Tilt		Fwd / Back - Up to 293" (7.44M)	deg 3 / 3
		Fwd / Back- 294" (7.46M) to 360" (9.14M)	deg 1 / 2
Lost Load Center	E		in/mm 12 / 305
Wheelbase	F		in/mm 69 / 1,753
Rear Overhang	G		in/mm 31.7 / 805
Overall Length Fork to Face	H	Mast Vertical	in/mm 113 / 2,870
Underclearance	I		in/mm 3 / 76
Operator Floor Height	J		in/mm 31 / 787
Overhead Guard Height	K		in/mm 89 / 2,261
Overhead Guard Width	L		in/mm 46 / 1,168
Overall Width	M		in/mm 56 / 1,422
Fork Carriage Width	N		in/mm 41 / 1,041
Fork Length	O		in/mm 40 / 1,041
Out to Out Fork Spread	P	Minimum/Maximum	in/mm 9.4-39.5 / 239-1,003
Battery Compartment Height	Q	Floor to Top of Battery Tray	in/mm 19 / 482.6
Right Angle Stacking Aisle		with 48"L x 40"W (1200mm x 1000mm) Load	in/mm 84 / 213
Intersecting Aisle		with 48"L x 40"W (1200mm x 1000mm) Load	in/mm 114 / 289
Gradeability		Loaded / Unloaded	% 15 / 15
Hydraulic Motor Rating		Continuous Duty Rating	type/kWh AC / 16.8
Traction Motor Rating		Continuous Duty Rating	type/kWh AC / 7.5 ea - 15 Total
Traction Control Type			AC
Hydraulic Control Type			AC
Wheel Sizes		Front (2 Each) Poly - Dia. x Face	in/mm 14x8 / 355.6x203.2
		Rear (2 Each) Rubber - Dia. x Face	in/mm 18x9 / 457.2x584.2

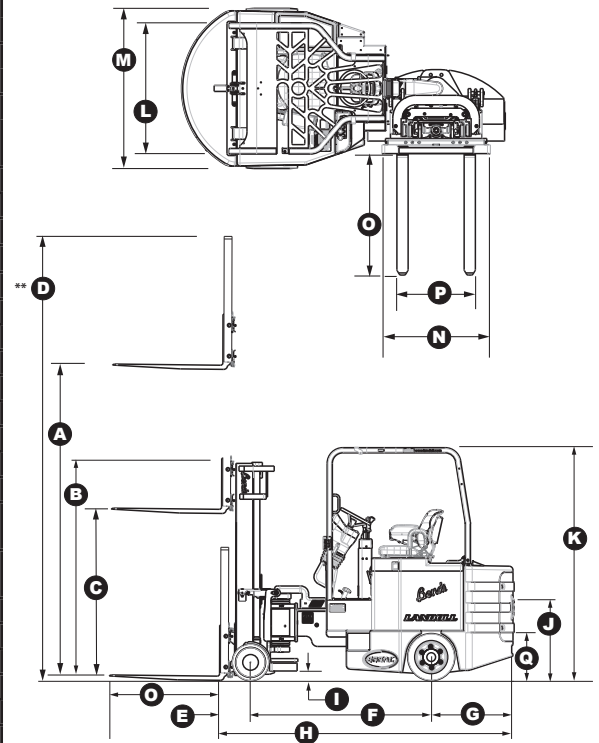

MAST DIMENSIONS

LIFT HEIGHT (A)		LOWERED HEIGHT (B)		** FREE LIFT (C)		OVERALL HEIGHT (D)	
Inches	Meters	Inches	Meters	Inches	Meters	Inches	Meters
Triple (3-Stage) Mast							
188	4.78	83	2.11	47	1.19	224	5.69
198	5.03	87	2.21	51	1.30	234	5.94
216	5.49	95	2.41	59	1.50	252	6.40
223	5.66	98	2.49	62	1.57	259	6.58
242	6.15	107	2.72	71	1.80	278	7.06
258	6.55	115	2.92	79	2.01	294	7.47
272	6.91	121	3.07	85	2.16	308	7.82
296*	7.52	129	3.28	93	2.36	332	8.43
312*	7.92	132	3.35	96	2.44	348	8.84
323*	8.20	138	3.51	102	2.59	359	9.12
360*	9.14	156	3.96	120	3.05	396	10.06
374*	9.50	167	4.24	131	3.33	410	10.40
Quad (4-Stage) Mast							
250	6.35	91	2.31	55	1.40	286	7.26
260	6.60	95	2.41	59	1.50	296	7.52
276	7.01	102	2.59	66	1.68	312	7.92
295*	7.49	109	2.77	73	1.85	331	8.41
315*	8.00	117	2.97	81	2.06	351	8.92
* Tilt Restricted to 1° Forward and 2° Backward							
** Free Lift Based on 36" (914mm) High Load Backrest							

AISLE DIMENSIONS

LOAD DEPTH X WIDTH	MINIMUM CLEAR AISLE
40" x 48" (1,000 x 1,200mm)	78" (1,930mm)
48" x 40" (1,200 x 1,000mm)	84" (2,134mm)
Transfer or End Aisle	114" (2,896mm)

RECOMMENDED BATTERY

BATTERY DESIGNATION: 24-85-23, 48 VOLT, 935 AHC (6 HOUR RATE)
Nominal Size: 44.75" x 32.25" x 22.63" (114 x 82 x 58cm)
Truck Compartment Size: 44.875" x 32.5" x 23" (114x83x59cm)
Battery Weight Min: 3,500 lbs. (1,590kg) Max: 4,000 lbs. (1,818kg)
Leads are at Position A, 12" (30.5cm) Long, with SB 350 Amp Blue Connector

Landoll continuously improves products. We reserve the right to make any changes in illustrations, specifications, equipment, and prices without prior notice and without changes on previous models.

QUALITY IS OUR FIRST PRIORITY



Exceptional Customer Support, Parts and Service

Landoll is committed to total customer satisfaction by providing products and services of the highest quality. Aftermarket parts and service is available world-wide through our factory trained dealer network and Landoll's service support department. Our 75,000 square foot Parts Distribution Center ensures quick and accurate delivery of parts to keep your equipment up and running. Experience for yourself the reason that Landoll Material Handling Products are #1 in customer retention.

Proven Solutions for Storage & Specialty Handling Applications

Family owned and operated since 1963, we make quality our first priority. Our goal is to provide the best solution for your material handling needs. Bendi articulating, Drexel SwingMast® Narrow Aisle and Very Narrow Aisle forklifts provide that solution. Through increased utilization of space, improved productivity, greater flexibility and maximized efficiency. We stay on the edge of modern and innovative technology. We know that for our customers "Quality is Always a Bargain".

FORKLIFT AISLE COMPARISON

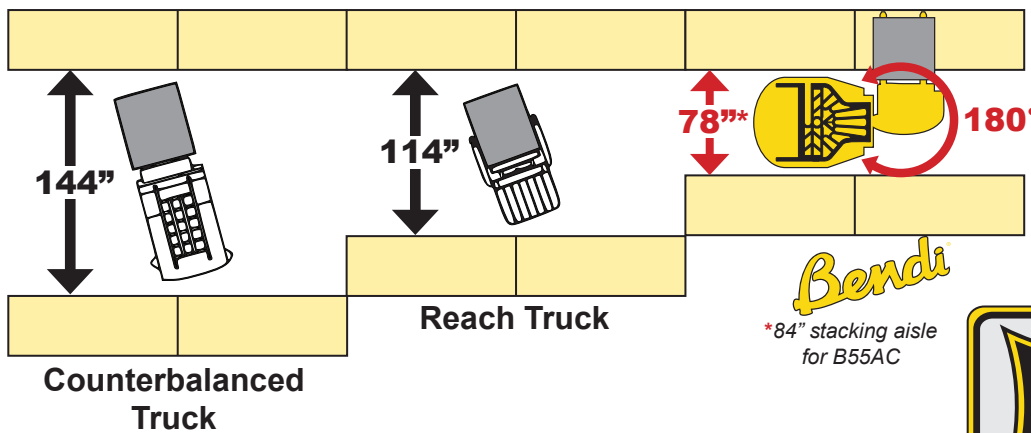

Bendi Narrow Aisle Forklifts save on warehouse space by **20%** compared to a reach truck and by **36%** compared to a counterbalanced truck.



MATERIAL HANDLING PRODUCTS

landoll.com/mhp

1900 North Street Marysville, KS 66508 · 800-428-5655 · forkliftsales@landoll.com



Landoll continuously improves products. We reserve the right to make any changes in illustrations, specifications, equipment, and prices without prior notice and without changes on previous models.

B30/40/55AC-0224