



KEY SPECS

Platform Height
34-ft 6.25-in / 10.5-m

Towing Speed
65 mph / 105 km/h

Horizontal Outreach
18-ft 9-in / 5.7-m

Platform Capacity
500-lb / 227-kg

KEY FEATURES

- Peak efficiency of 4 x 6v 220 amp-hr batteries for quiet, efficient power.
- New standard features include a smart charger, LED tail lights, lockable hoods, dual USB port in platform and parking brake audible indicator
- Set up with ease and get right to work with hydraulic, auto-leveling outriggers.
- Detachable platform controls provide efficient boom positioning with one-hand operation of all boom functions.

ACCESSORIES & OPTIONS

- 3000W Honda Generator (Aftermarket Only)
- Full-Size Spare Tire
- Lifting Lugs
- Material Hook — 500-lb / 227-kg Capacity
- Platform Rotator

STANDARD SPECIFICATIONS

Performance

Platform Height	34-ft 6.25-in / 10.5-m
Horizontal Outreach	18-ft 9-in / 5.7-m
Centerline to Platform Edge	20-ft / 6.1-m
Swing	410 Degrees Non-Continuous
Platform Capacity	500-lb / 227-kg
Platform Capacity w/Rotator (Optional)	440-lb / 200-kg
Material Hook Capacity	500-lb / 227-kg
Platform Rotator	90 Degrees Manual
Weight*	3,600-lb / 1,542-kg
Leveling Capability	11 Degrees
Max. Ground Bearing Pressure	23 psi / 1.62 kg/cm ²
Towing Speed Rating	65 mph / 105 km/h
Tongue Weight*	250-lb / 114-kg
Max Gradability	20%
Hydraulic Reservoir	4.0 gal / 15.14 L

*Certain options or country standards increase weight

Power Source

DC Power	24V DC
Batteries	4 x 6V 220 amp-hr

Tires

Standard	ST215/75 R14 Pneumatic
----------	------------------------

STANDARD FEATURES

- 110V-AC Receptacle in the Platform
- 2-in Hitch with Adjustable Height Coupler
- Amber Beacon
- ANSI A92.2 Compliant
- Auto-Leveling Hydraulic Outriggers
- Dual USB Port in Platform
- Hourmeter
- Hydraulic Surge Brakes
- LED Taillights & Mounting Bracket
- Lockable Battery Covers
- Lockable Hoods
- Motion Alarm
- Parking Brake Audible Indicator
- Platform, Side Entry: 30 x 48-in (0.76 x 1.22-m)
- Proportional Controls
- Quick Start Guide Common Among all JLG® Towable Boom Models
- Standard Air and Water Lines to Platform
- Smart Charger
- Telescopic Upper Boom
- Tilt Alarm/Indicator Light

DIMENSIONS

All dimensions are approximate

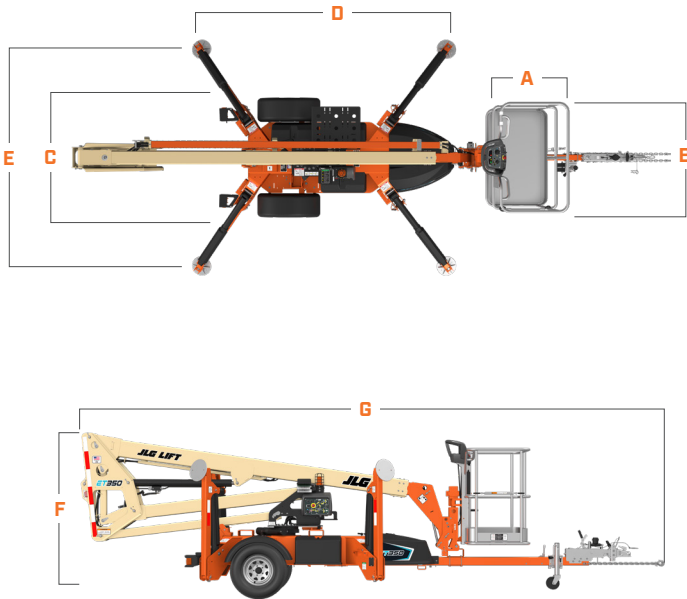

- A. Platform Width 30-in / 0.76-m
- B. Platform Length 48-in / 1.22-m
- C. Machine Width 5-ft 2.75-in / 1.6-m
- D. Outrigger Footprint Length 11-ft 7-in / 3.5-m
- E. Outrigger Footprint Width 10-ft 5-in / 3.2-m
- F. Machine Height 6-ft 7-in / 2.0-m
- G. Machine Length 21-ft 9.5-in / 6.6-m¹

¹ With surge brake, 2-in ball

REACH DIAGRAM

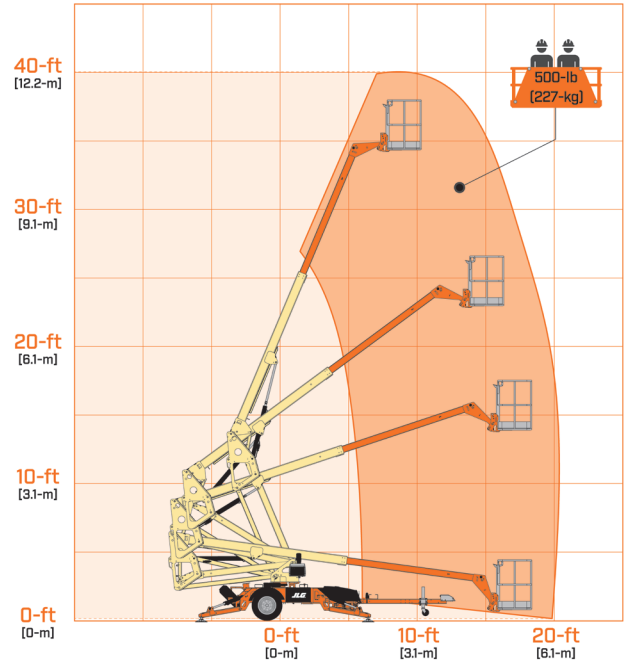

(844) 432-4724

fairchildequipment.com



We provide coverage for one (1) full year, and cover all specified major structural components for five (5) years. Due to continuous product improvements, we reserve the right to make specification and/or equipment changes without prior notification. This machine meets or exceeds applicable ANSI and CSA requirements based on machine configuration as originally manufactured for intended applications. Please reference the serial number plate on the machine for additional information.



JLG INDUSTRIES, INC.
Toll-free US 877-JLG-LIFT
JLG.com

An Oshkosh Corporation Company