

EC600SJP

ELECTRIC BOOM

BOOM LIFT



KEY SPECS

Platform Height
60-ft 4-in / 18.39-m

Horizontal Outreach
44-ft 5-in / 13.54-m

Drive Speed
3.0 mph / 4.8 km/h

Platform Capacity
500-lb / 227-kg

KEY FEATURES

- Peak productivity with 60-ft 4-in platform height and 44-ft 5-in horizontal outreach.
- Produces zero emissions, emits reduced sound and utilizes non-marking tires.
- Achieve maximum maneuverability by moving over uneven surfaces with Automatic Traction Control.
- Achieve optimum productivity with longer duty cycles.

ACCESSORIES & OPTIONS

- AGM Batteries, 390 amp-hr
- Bolt-on Fall Arrest System
- Hostile Environment Kit¹
- Inverter - 1200W or 3000W
- Light Package²
- Platform Mesh to Mid or Top Rail^{3,4}
 - Aluminum or Plastic
- Platforms
 - Drop Bar, 30 x 36-in, 30 x 48-in, 30 x 72-in
 - Inward Self-Closing Swing Gate, 30 x 48-in, 30 x 72-in, 36 x 72-in
 - Tri-Entry Drop Bar or Swing Gate, 36 x 72-in
- SkySense[®] Enhanced Detection System⁵
- Soft Touch System⁴
 - Self-Closing Swing Gate, Drop Bar, 36 x 72-in
- Storage Tray - Center or Corner
- UL[®] EE Rating

STANDARD SPECIFICATIONS

Performance

Platform Height	60-ft 4-in / 18.39-m
Horizontal Outreach	44-ft 5-in / 13.54-m
Swing	400 Degrees Non-Continuous
Platform Capacity	500-lb / 227-kg
Platform Rotator	180 Degrees Hydraulic
Jib Range of Articulation (Vertical)	145 Degrees (+89, -56)
Jib Range of Articulation (Horizontal)	180 Degrees (+90, -90)
Weight*	17,210-lb / 7,807-kg
Max. Ground Bearing Pressure	51 psi / 3.6 kg/cm ²
Drive Speed	3.0 mph / 4.8 km/h
Gradeability (2WD)	30%
Gradeability (4WD)	45%
Turning Radius Inside (2WS/4WS)	4-ft / 1.22-m
Turning Radius Outside (2WS/4WS)	15-ft 2.5-in / 4.64-m

Power Source

Electrical System	48V DC
Batteries	8 x 6V, 415 amp-hr
Drive Motors	Dual Electric Traction

Tires

Standard	36 x 14-22.5 Non-Marking Foam-filled
----------	--------------------------------------

Hydraulic System

Capacity	15 gal / 56.78 L
Motor/pump	Series Wound Motor/Gear Pump

STANDARD FEATURES

- 4 Degree Tilt Cut-out
- 6-ft (1.83-m) Articulating Jib
- 110V-AC GFI Receptacle in the Platform
- All Motion Alarm
- Automatic Traction Control
- Battery Condition Indicator
- ClearSky Smart Fleet™ Hardware (CS550)**
- Hourmeter
- LED Motion/Amber Beacon (CS550)**
- Lifting/Tie Down Lugs
- Load Sensing System
- Manual Descent
- Oscillating Axle
- Platform Console Machine Status Light Panel***
- Removable Battery Box
- SCR Automatic Battery Charger
- SkyGuard SkyLine™
- Tilt Light and Alarm

*Certain options or country standards increase weight.

**Standard beacon and ClearSky Smart Fleet hardware availability varies by model throughout 2023.

***Provides indicator lights at platform control console for system distress, low fuel, degree tilt light and foot switch status.

1. Includes Console Cover, Boom Wipers and Cylinder Bellows.

2. Includes Head and Tail Lights, Platform Worklight.

3. Requires Self-Closing Gate.

4. Not Compatible with Bolt On Fall Arrest, Platform Mesh, Platform Rail Extensions, SkySense, or Soft Touch (Excludes Option Noted).

5. Not Compatible with Bolt On Fall Arrest.

Additional Accessories and Options Available Via JLG Aftermarket.



EC600SJP

ELECTRIC BOOM

BOOM LIFT



DIMENSIONS

All dimensions are approximate

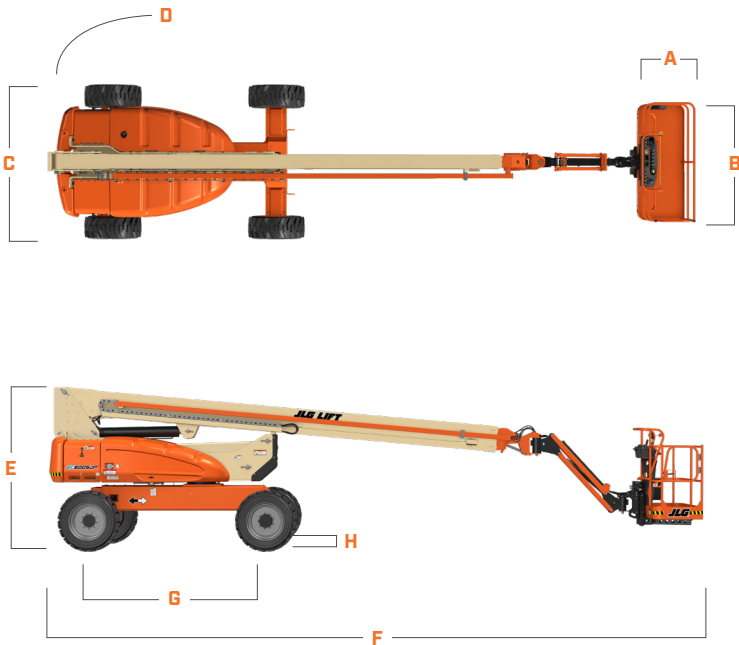

REACH DIAGRAM

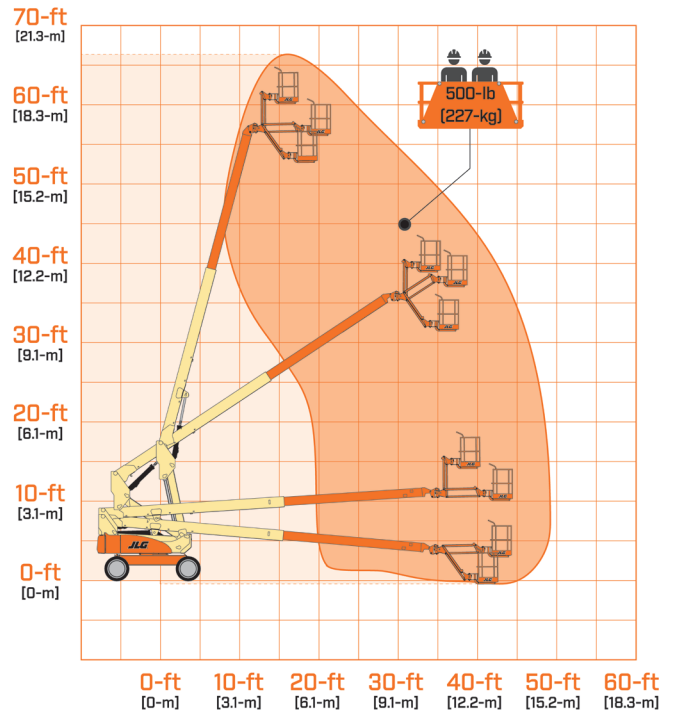

- A. Platform Width 30-in / 76-cm
- B. Platform Length 72-in / 1.83-m
- C. Machine Width 7-ft 11-in / 2.41-m
- D. Tailswing 4-ft / 1.22-m
- E. Machine Height 8-ft 4-in / 2.54-m
- F. Machine Length 33-ft 4-in / 10.16-m
- G. Wheelbase 9-ft / 2.74-m
- H. Ground Clearance 14-in / 36-cm



(844) 432-4724

fairchildequipment.com



We provide coverage for one (1) full year, and cover all specified major structural components for five (5) years. Due to continuous product improvements, we reserve the right to make specification and/or equipment changes without prior notification. This machine meets or exceeds applicable ANSI and CSA requirements based on machine configuration as originally manufactured for intended applications. Please reference the serial number plate on the machine for additional information.



JLG INDUSTRIES, INC.
Toll-free US 877-JLG-LIFT
JLG.com

An Oshkosh Corporation Company