

660SJ

TELESCOPIC BOOM LIFT

BOOM LIFT



KEY SPECS

Platform Height
65-ft 8-in / 20.02-m

Horizontal Outreach
57-ft 1-in / 17.40-m

Drive Speed
3.8 mph / 6.1 km/h

Platform Capacity
Restricted: 750-lb / 340-kg
Unrestricted: 550-lb / 249-kg

KEY FEATURES

- One of the most popular JLG 60-ft boom lifts.
- Utilizes intuitive platform controls to reduce operator training time.
- Delivers a zero calibration automatic load sensing system that eliminates the need to use external weights to calibrate the machine.
- Available accessories and options provide the flexibility to upfit the machine to meet unique job requirements.

ACCESSORIES & OPTIONS

- 1/2-in Air Line to Platform
- AC Generator, 2500W or 4000W
- Accessory Packages
 - SkyGlazier® Package
 - SkyPower® Package
 - SkyWelder® Package
- Arctic Package¹
- Bolt On Fall Arrest System
- Cold Weather Package²
- Hostile Environment Package³
- Light Package
- Platform Mesh to Mid or Top Rail
 - Aluminum or Plastic
- Platforms
 - Drop Bar, 30 x 36-in, 30 x 48-in, 30 x 60-in, 36 x 72-in, 36 x 96-in
 - Fall Arrest, Rear Entry, 36 x 72-in, 36 x 96-in
 - Inward Self-Closing Swing Gate, 30 x 48-in, 30 x 60-in, 36 x 72-in, 36 x 96-in
- Tri-Entry, Drop Bar or Swing Gate, 36 x 72-in, 36 x 96-in
- SkySense® Enhanced Detection System
- Soft Touch System
- Storage Tray - Center or Corner

STANDARD SPECIFICATIONS

Performance

Platform Height	65-ft 8-in / 20.02-m
Horizontal Outreach	57-ft 1-in / 17.40-m
Swing	360 Degrees Continuous
Platform Capacity (Restricted)	750-lb / 340-kg
Platform Capacity (Unrestricted)	550-lb / 249-kg
Platform Rotator	180 Degrees Hydraulic
Jib Length	6-ft / 1.83-m
Jib Range of Articulation	132 Degrees (+71, -61)
Weight*	25,341-lb / 11,494-kg
Max. Ground Bearing Pressure	86 psi / 6.00 kg/cm ²
Drive Speed	3.8 mph / 6.1 km/h
Gradeability	45%
Tilt Cut Out	5 Degrees
Axle Oscillation	8-in / 0.2-m
Turning Radius 2WS (Inside/Outside)	Inside: 9-ft 7-in / 2.92-m Outside: 19-ft 7-in / 5.96-m
Turning Radius 4WS (Inside/Outside)	Inside: 5-ft 3-in / 1.61-m Outside: 12-ft 8-in / 3.87-m

Engine

Dual Fuel – Ford MSG425-DF	84 hp / 62.6 kW
Diesel Fuel – Deutz D2.9L4 Tier 4 Final	48.8 hp / 36.4 kW
Fuel Tank Capacity	31 gal / 117 L

Tires

Standard	Foam Filled, 14(IN355)X17.5(55D625)
Optional	Foam Filled Non-Marking, 14(IN355)X17.5(55D625) Foam Filled, Turf & Sand, 41/18LLx22.5 Quad Tracks

Hydraulic System

Hydraulic Reservoir	34 gal / 129 L
Auxiliary Power	12V DC

STANDARD FEATURES

- 5 Degree Tilt Alarm / Indicator Light
- 12V-DC Auxiliary Power
- 110V-AC Receptacle in the Platform
- 180 Degree Hydraulic Platform Rotator
- ClearSky Smart Fleet™ Hardware (CS550)**
- Control ADE® System
- Four-Wheel Hydrostatic Drive
- Glow Plugs (Diesel Engines)
- Horn
- Hourmeter
- Improved Multi-Function Controls
- Interactive Display at Ground Controls
- LED Motion / Amber Beacon (CS550)**
- Lifting / Tie Down Lugs
- Motion Alarm
- Oscillating Axle
- Platform Console Machine Status Light Panel***
- Proportional Controls
- SkyGuard SkyLine™
- Swing-Out Engine Tray

*Certain Options or Country Standards Increase Weight.

**Standard Beacon and ClearSky Smart Fleet Hardware Availability Varies by Model Throughout 2023.

***Provides Indicator Lights at Platform Control Console for System Distress, Low Fuel, Degree Tilt Light and Foot Switch Status.

1. Includes arctic hydraulic hoses (drive and steer only) and main boom cable, arctic hydraulic oil, extreme cold engine oil, fuel conditioner, engine block heater, battery blanket, glow plugs, hydraulic tank heater, and oversized footswitch.
2. Includes battery blanket, hydraulic tank heater, block heater.
3. Includes console cover, boom wipers and cylinder bellows.

Note: Some options may increase lead time, and some option combinations may not be available. Additional accessories and options available via JLG Aftermarket.



660SJ

TELESCOPIC BOOM LIFT

BOOM LIFT



DIMENSIONS

All dimensions are approximate

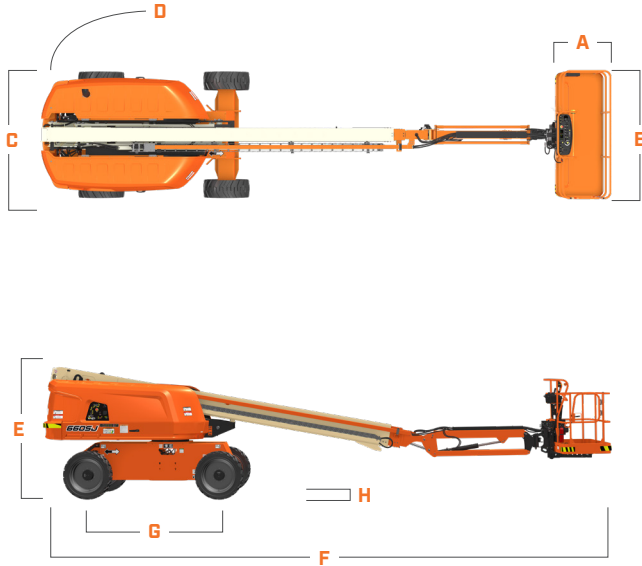

A.	Platform Width	36-in / 0.91-m
B.	Platform Length	96-in / 2.44-m
C.	Machine Width	8-ft 2-in / 2.48-m
D.	Tailswing	4-ft / 1.22-m
E.	Machine Height	8-ft 2.4-in / 2.50-m
F.	Machine Length	35-ft 4.7-in / 10.79-m
G.	Wheelbase	8-ft 2.7-in / 2.5-m
H.	Ground Clearance	11.3-in / 29-cm

REACH DIAGRAM

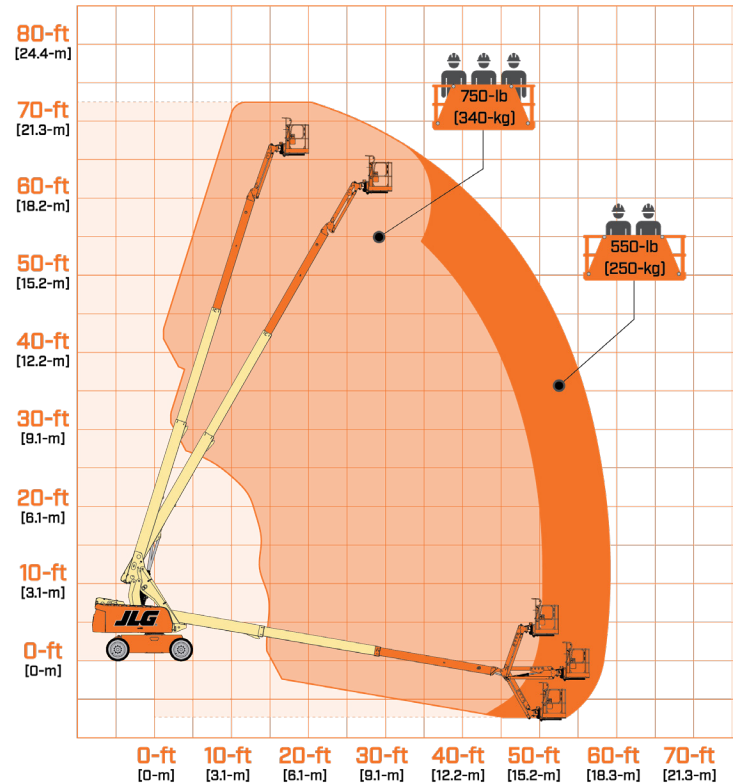

(844) 432-4724

fairchildequipment.com



We provide coverage for one (1) full year, and cover all specified-major structural components for five (5) years. Due to continuous product improvements, we reserve the right to make specification and/or equipment changes without prior notification. This machine meets or exceeds applicable ANSI and CSA requirements based on machine configuration as originally manufactured for intended applications. Please reference the serial number plate on the machine for additional information.



JLG INDUSTRIES, INC.
Toll-free US 877-JLG-LIFT
JLG.com

An Oshkosh Corporation Company