

COMBILIFT 25
LIFTING INNOVATION *Years*



COMBi-AGT

Autonomous Guided Truck

The first autonomous guided forklift truck with optional manual operation

Safely and reliably deliver long loads in narrow aisle around the clock with the new Combi-AGT



combilift.com

COMBi-AGT

Autonomous Guided Truck

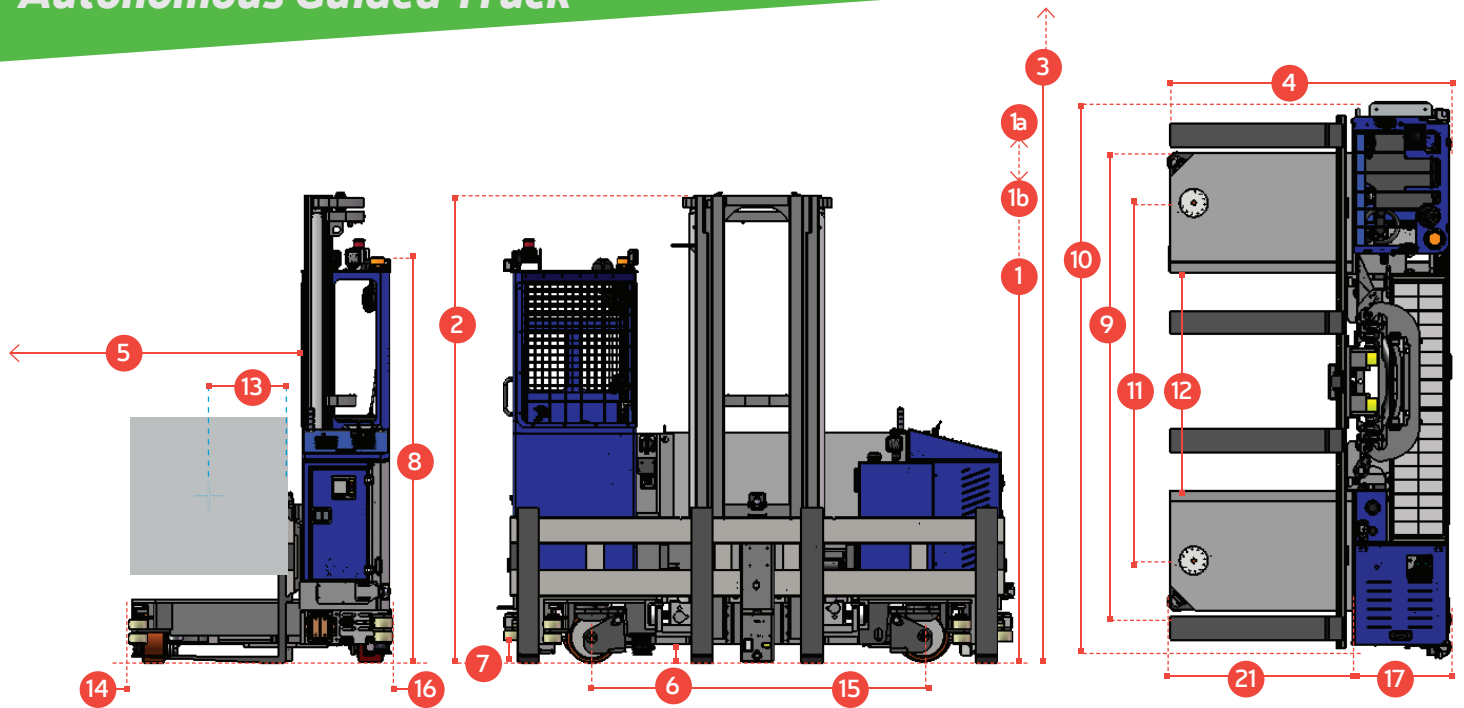

REF.	DESCRIPTION	6000	11000
1a	Max. Lift Height		236"
1b	Free Lift Height		150"
2	Height Mast Closed		157"
3	Max. Mast Raised		279"
4	Overall Length	50"	54"
5	Mast travel		27½"
6	Ground Clearance Under Mast		5"
7	Ground Clearance to Center of Wheelbase		5"
8	Height Over Cab (without work lights)		118"
9	Width		116¼"
10	Outside Spread of Fork Arms		53"
11	Wheelbase		90½"
12	Frame Opening		55"
13	Load Center Distance		12"
14	Overhang Front		6"
15	Track	38½"	42½"
16	Overhang Back		5½"
17	Length from Face of Fork	26"	30"
20	Platform Height (with front lowered)		16½"
21	Platform Length		24"
22	Overall Width		135"
A	Capacity	6,000 lbs	11,000 lbs
B	Unladen Weight	19,000 lbs	20,500 lbs
D	Gradeability		10%
E	Battery Capacity		72V 420Ah

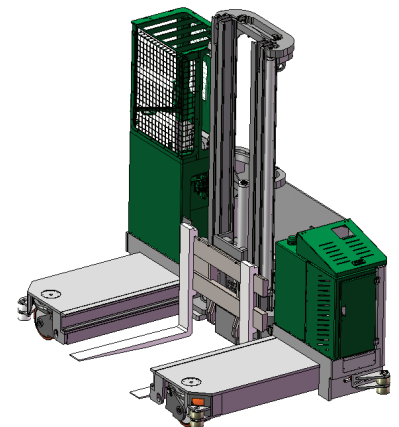

Features Include:

- 4 Wheel Steering
- Load Sensing Steering
- 2 Wheel Drive
- Tilting Chassis +/- ½" at front

Optional:

- Barcode scanning

Distributed by:



(844) 432-4724

fairchildequipment.com

COMBILIFT HAS A POLICY OF CONTINUOUS PRODUCT DEVELOPMENT AND RESERVES THE RIGHT TO ALTER SPECIFICATIONS WITHOUT PRIOR NOTICE. SPECIFICATIONS AND/OR DIMENSIONS MAY VARY FROM THOSE ILLUSTRATED IN SOME COUNTRIES.

combilift.com