

SJ3013 micro ELECTRIC SCISSOR



STANDARD FEATURES

- Drivable at full height
- Variable speed, rear wheel electric drive
- Dual holding brakes
- Upper control box with integrated steel shroud
- Tilt Sensor (3.5° x 2.5°)
- 20" (0.51 m) Roll out extension deck
- 24V DC power source
- Low voltage battery protection
- 25% Gradeability
- Solid rubber, non-marking tires
- Pothole protection system
- Tilt alarm with drive & lift cut-out
- Lowering alarm
- Lanyard attachment points
- Operator horn
- Forklift pockets and tie down/lift lugs
- Overload sensing system
- Fold down hinged railing system
- Overall machine height under 80" (stowed)
- Maintenance free Gel batteries
- Flashing lights
- Locking battery tray
- Pull-out tray for easy access
- Hydraulic oil level indicator
- Battery level indicator

OPTIONS ‡

- ECOTRAY leak containment system
- Telematics



‡ Standard lead times may be increased when optional equipment is added, consult factory.
Capacities and machine weights may differ when options are added.

SJ3013 micro ELECTRIC SCISSOR

| Dimensions | Imperial | Metric |
|--|-------------------|------------------------|
| A Work Height | 18' 10" | 5.75 m |
| B Raised Platform Height | 12' 10" | 3.90 m |
| C Overall Width | 30" | 0.76 m |
| D Overall Length | 59" | 1.49 m |
| E Stowed Height (Rails Up) | 79.5" | 2.02 m |
| F Stowed Height (Rails Down) | 63" | 1.59 m |
| G Platform Width (Inside Dimension) | 30" | 0.76 m |
| H Platform Length (Inside Dimension) | 50" | 1.28 m |
| Specifications | | |
| Extension Deck (Roll Out) | 20" | 0.51 m |
| Ground Clearance (Pothole Raised) | 2.4" | 6 cm |
| Wheelbase | 41" | 1.05 m |
| Weight | 2095 lbs | 950 kg |
| Gradeability | 25% | |
| Turning Radius (Inside) | 14" | 0.35 m |
| Lift Time (With Rated Load) | 25 sec | |
| Lower time (With Rated Load) | 18 sec | |
| Drive Speed (Stowed) | 1.9 mph | 3.0 km/h |
| Drive Speed (Raised) | 0.5 mph | 0.8 km/h |
| Maximum Drive Height | Full Height | |
| Capacity (Overall) | 500 lbs | 227 kg |
| Distributed Capacity (Extension Deck) | 220 lbs | 100 kg |
| Local Floor Load (With Rated Load) | 82 psi | 565 kPa |
| Overall Floor Load (With Rated Load) | 271 psf | 1322 kg/m ² |
| Maximum # of persons at 0 mph (0 m/s) wind rating | 2 | |
| Maximum # of persons up to 28 mph (12.5 m/s) wind rating | 1 | |
| Tire Type | Solid rubber, N/M | |
| Tire Size | 9 x 3 | |

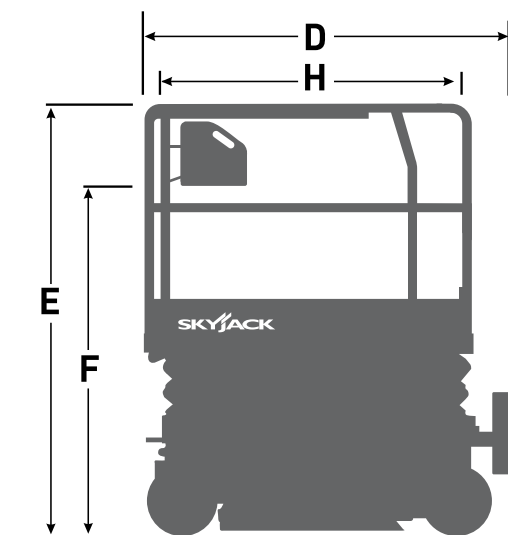
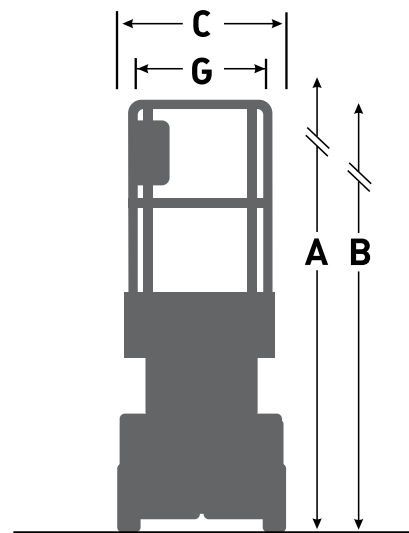

(844) 432-6100

fairchildequipment.com

www.skyjack.com

