



Daily & Weekly Maintenance Guide



Turn Off Power, Remove Key Before Servicing

Daily Mo Tu We Th Fr Sa Su Or 5 hrs

1

Drain / Rinse Recovery

2

Inspect Curtains / Side Wipers

3

Inspect / Clean Lids

4

Inspect / Clean Squeegee

5

Inspect / Clean Brushes / Pads

6

Empty Solution Tank

7

Empty & Clean Front Fill Screen

8

Charge Batteries

8

Charge Batteries

Weekly Mo Tu We Th Fr Sa Su Or 25 hrs

1

Inspect Hoses

2

Inspect Casters / Wheels

3

Clean Float Ball / Filter / Screen

4

Rotate Brushes / Cylindricals

5

Inspect Funnel Drain

6

Inspect / Clean Solution Filter

7

Wipe Down Machine

No Pressure Wash / Chemicals

8

Inspect Battery Water Level

LEAD (Pb)

Battery Connection Guide

Do Not Exceed 11 ft/lb Torque (7 Nm)

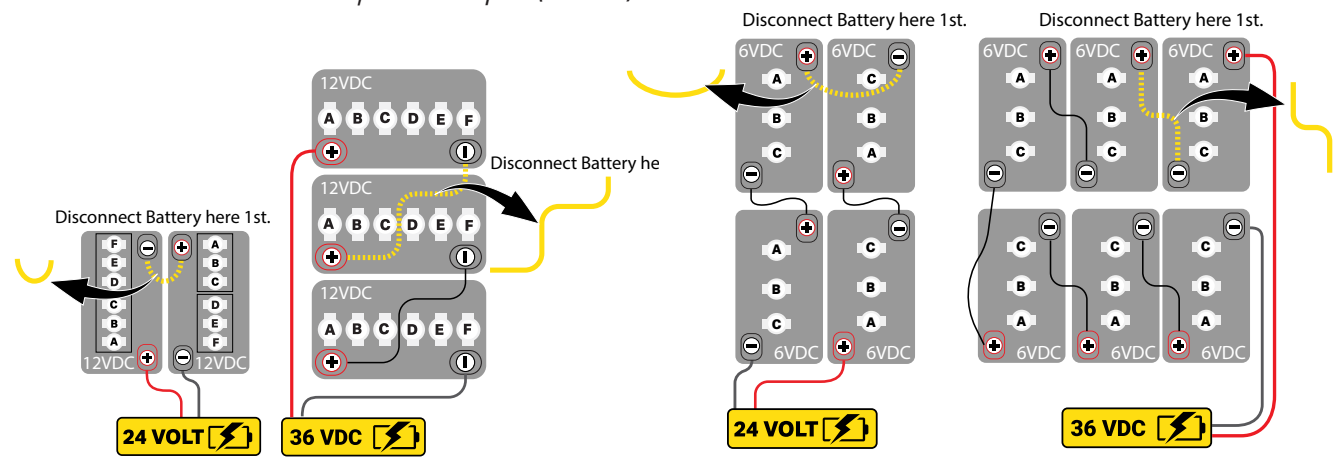

For Expert Support Contact Authorized Distributor...



(844) 432-4724

fairchildequipment.com