

X500AJ

COMPACT CRAWLER

BOOM LIFT



KEY SPECS

Platform Height

49-ft / 14.95-m

Horizontal Outreach

23-ft / 7-m

Platform Capacity

500-lb / 227-kg

Overall Width

31-in / 0.78-m

KEY FEATURES

- Best-in-class 500-lb unrestricted platform capacity.
- Environmentally friendly with standard AC powered boom functions, gas or an optional lithium-ion electrical system for emission-free operation.
- Access tight spaces and climb slopes with ease thanks to a narrow chassis and tracked wheel carriage.
- Transport with ease by a forklift or crane with forklift pockets and lifting eyes, and fits through standard doorway.

STANDARD SPECIFICATIONS

Performance

Platform Height	49-ft / 14.95-m
Horizontal Outreach	23-ft / 7-m
Platform Capacity	500-lb / 227-kg
Swing	360 Degrees Non-continuous
Platform Rotation	124 Degrees (+62, -62 Degrees)
Jib (Range of Articulation)	89 Degrees (0, -89 Degrees)
Ground Bearing Pressure (Tracks)	9.72 psi / .68 kg/cm ²
Ground Bearing Pressure (Outriggers)	35.53 psi / 2.49 kg/cm ²
Drive Speed	.8 mph / 1.3 km/h
Max Approach / Depart Angles	20° / 21°
Gradeability	28%
Weight* (Diesel)	5,071-lb / 2,300-kg

*Certain options or country standards increase weight

Power

Engine: Honda iGX390	11.7 hp / 8.7 kW
Fuel Tank Capacity	1.5 gal / 5.9 L
AC Motor	120V AC / 60 HZ
Optional: 48V Lithium Ion Battery	48V / 90Ah

Tracks

Standard	Non-marking Tracks
----------	--------------------

Hydraulic System

Capacity	10.56 gal / 40 L
----------	------------------

STANDARD FEATURES

- 110V-AC receptacle in Platform
- Below Grade Capability
- Caster Platform Wheels
- Color Remote and Ground Panel Provides On-board Diagnostics
- Flashing Amber Beacon
- Fork Pockets and Lifting Hooks
- Fully Synthetic Biodegradable Hydraulic Fluid
- Large Teflon® Outrigger Pads
- Multi-Position Outriggers
- One-touch Outrigger Leveling
- Patented Quick Disconnect Platform
- QuikStik®
- SkyGuard SkyLine™
- Standard Air/Water Line

ACCESSORIES & OPTIONS

- Black Deep-Tread Tracks
- Platform, Single-Person 31 x 24-in

X500AJ

COMPACT CRAWLER

BOOM LIFT



DIMENSIONS

All dimensions are approximate

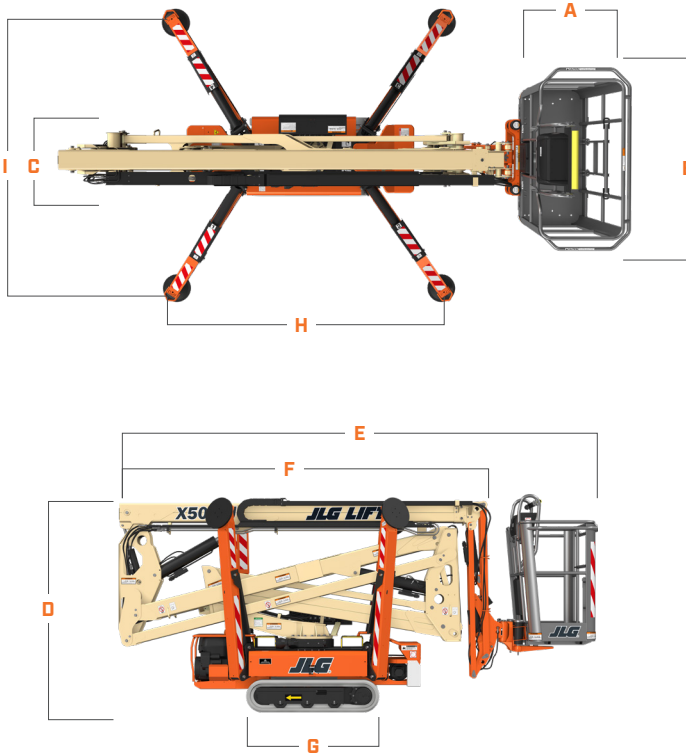

- | | |
|---|----------------------|
| A. Platform Width | 30-in / 76-cm |
| B. Platform Length | 58-in / 1.47-m |
| C. Machine Width | 31-in / 78-cm |
| D. Machine Height | 6-ft 6-in / 1.98-m |
| E. Machine Length | 14-ft 10-in / 4.53-m |
| F. Machine Length Without Platform | 13-ft 8-in / 4.16-m |
| G. Track length | 4-ft 1-in / 1.24-m |
| H. Outrigger Footprint Length | 10-ft 5-in / 3.17-m |
| I. Outrigger Footprint Width | 10-ft 5-in / 3.17-m |
| J. Outrigger Pad Diameter | 11.8-in / 30-cm |

REACH DIAGRAM

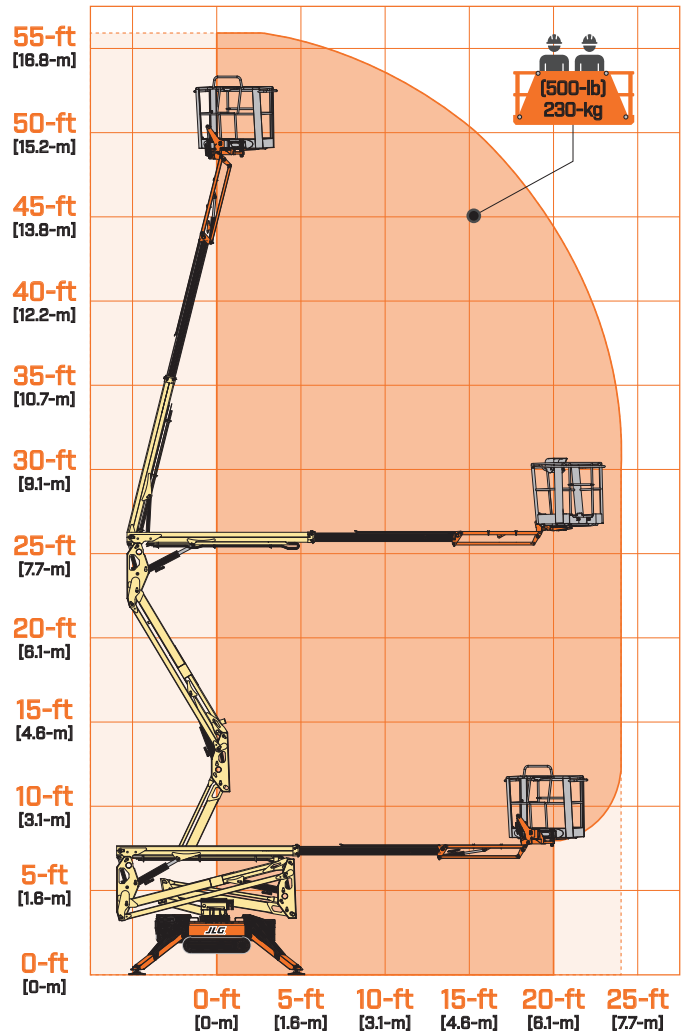

(844) 432-4724

fairchildequipment.com



We provide coverage for one (1) full year, and cover all specified major structural components for five (5) years. Due to continuous product improvements, we reserve the right to make specification and/or equipment changes without prior notification. This machine meets or exceeds applicable ANSI and CSA requirements based on machine configuration as originally manufactured for intended applications. Please reference the serial number plate on the machine for additional information.



JLG INDUSTRIES, INC.
Toll-free US 877-JLG-LIFT
JLG.com

An Oshkosh Corporation Company