



## STANDARD SPECIFICATIONS

### Performance

Platform Height	50-ft 9.5-in / 15.3-m
Horizontal Outreach	31-ft 6-in / 9.6-m
Centerline to Platform Edge	31-ft / 9.45-m
From Outrigger Pad Edge	25-ft / 7.62-m
Up and Over Height	18-ft / 5.49-m
Swing	410 Degrees Non-Continuous
Platform Capacity	500-lb / 227-kg
Platform Capacity w/Rotator (optional)	440-lb / 200-kg
Material Hook Capacity	500-lb / 227-kg
Platform Rotator	90 Degrees Manual
Jib Length	4-ft / 1.22-m
Jib Vertical Motion	130 Degrees (+75, -55)
Weight*	4,800-lb / 2,177-kg
Leveling Capability	11 Degrees
Max. Ground Bearing Pressure	31 psi / 2.18 kg/cm <sup>2</sup>
Towing Speed Rating	65 mph / 105 km/h
Tongue Weight*	350-lb / 159-kg
Max Gradability	20%

\*Certain options or country standards increase weight

### Power Source

DC Power	24V DC
Batteries	4 x 6V 220 amp-hr
Gasoline Engine (Optional)	9 hp

### Tires

Standard	ST225/75 R15 Pneumatic
----------	------------------------

### KEY SPECS

**Platform Height**  
50-ft 9.5-in / 15.3-m

**Up and Over Height**  
18-ft / 5.49-m

**Horizontal Outreach**  
31-ft 6-in / 9.6-m

**Platform Capacity**  
500-lb / 227-kg

### KEY FEATURES

- Choose from a gasoline engine or 24V DC electric power to fit your unique job needs.
- Increase productivity with standard features such as air and water lines to the platform and an accessory mounting tray.
- Set up with ease and get right to work with hydraulic, auto-leveling outriggers.
- Detachable platform controls provide more efficient boom positioning with one-hand operation of all boom functions.

## STANDARD FEATURES

- 110V-AC Receptacle in the Platform
- 2-in Hitch with Adjustable Height Coupler
- Auto-Leveling Hydraulic Outriggers
- Battery Condition Indicator
- Four 6V 220 Amp-Hour Batteries
- Hourmeter
- Motion Alarm
- Parking Brake
- Platform, Side Entry: 30 x 48-in (0.76 x 1.22-m)
- Proportional Controls
- Standard Air and Water Lines to Platform
- Telescopic Upper Boom
- Tilt Alarm/Indicator Light

## ACCESSORIES & OPTIONS

- 3000W Honda Generator
- Amber Beacon
- Drive and Outrigger Set
- Full-Size Spare Tire
- Lifting Lugs
- Material Hook — 500-lb / 227-kg Capacity
- Non-Marking Outrigger Pads
- Platform Rotator
- Wheel Chocks

## DIMENSIONS

All dimensions are approximate

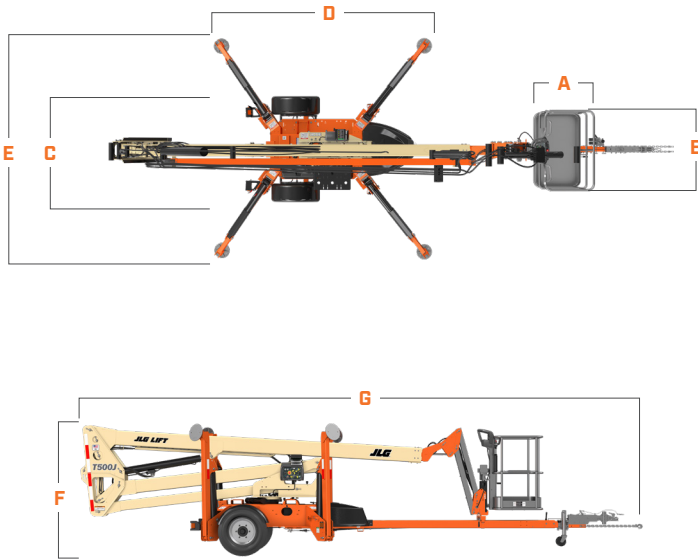

- A. Platform Width 30-in / 0.76-m
- B. Platform Length 48-in / 1.22-m
- C. Machine Width 5-ft 10-in / 1.8-m
- D. Outrigger Footprint Length 12-ft 4-in / 3.8-m
- E. Outrigger Footprint Width 12-ft 8-in / 3.8-m
- F. Machine Height 6-ft 7-in / 2-m
- G. Machine Length 27-ft 4-in / 8.32-m<sup>1</sup>

1. With surge brake, 2-in ball

## REACH DIAGRAM

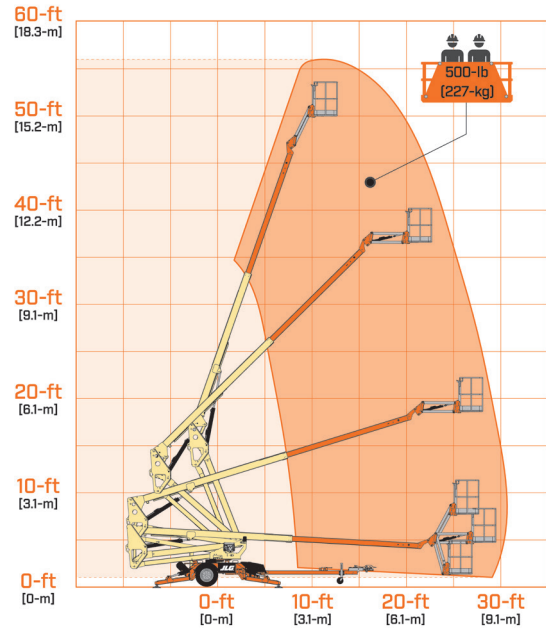

(844) 432-4724

[fairchildequipment.com](http://fairchildequipment.com)



We provide coverage for one (1) full year, and cover all specified major structural components for five (5) years. Due to continuous product improvements, we reserve the right to make specification and/or equipment changes without prior notification. This machine meets or exceeds applicable ANSI and CSA requirements based on machine configuration as originally manufactured for intended applications. Please reference the serial number plate on the machine for additional information.



JLG INDUSTRIES, INC.  
Toll-free US 877-JLG-LIFT  
JLG.com

An Oshkosh Corporation Company