

RT4769

ENGINE POWERED ROUGH TERRAIN SERIES

SCISSOR LIFT



STANDARD SPECIFICATIONS

Performance	Indoor	Outdoor
Platform Height (Elevated)	47-ft / 14.3-m	47-ft / 14.3-m
Platform Capacity	800-lb / 363-kg	800-lb / 363-kg
Capacity on Platform Extension	300-lb / 136-kg	300-lb / 136-kg
Number of Occupants	3	3
Lift / Lower Time	65/60 seconds	65/60 seconds
Maximum Drive Height	Fully Elevated	Fully Elevated
Weight w/One Extension*	15,200-lb / 6,909-kg	15,200-lb / 6,909-kg
Drive Speed (Lowered)	3.0 mph / 4.82 km/h	3.0 mph / 4.82 km/h
Drive Speed (Raised)	0.3 mph / .48 km/h	0.3 mph / .48 km/h
Gradeability	35%	35%
Max Tilt Rating (Side-to-Side)	2.5 Degrees	2.5 Degrees
Max Tilt Rating (Fore and Aft)	3 Degrees	3 Degrees
Turning Radius (Inside)	83-in / 2-m	83-in / 2-m
Turning Radius (Outside)	175-in / 4-m	175-in / 4-m

*Certain options or country standards increase weight

KEY SPECS

Platform Height

47-ft / 14.3-m

Machine Width

69.3-in / 1.76-m

Platform Capacity

800-lb / 363-kg

Stowed Drive Speed

3.0 mph / 4.82 km/h

KEY FEATURES

- Our engine powered rough terrain models offer drive capability at full height, limiting unnecessary trips up and down for working professionals.
- Delivers the latest technology, featuring an LCD platform control box with LiftSense technology and USB charging for next-level, real-time productivity and service communication to the operator.
- This machine utilizes higher part commonality for simplified service across the rough terrain family.
- An optional QuikLevel Advanced system allows the machine to level on a side slope, helping operators position and drive while elevated closer to the job.

Engine

Dual Fuel – Kubota WG972-GL-E4 31 hp	31 hp / 23.2 kW
Diesel Fuel – Kubota D1305-E4B 24.8 hp	24.8 hp / 18.5 kW
Fuel Tank Capacity	10 gal / 38 L

Tires

Standard	26 x 12-in Foam-filled
----------	------------------------

Brakes

Rear Wheel	Spring Applied
------------	----------------

Hydraulic System

Capacity	13.2 gal / 50 L
----------	-----------------

STANDARD FEATURES

- 110V-AC Receptacle In Platform
- 26 x 12 Foam-filled Tires
- 42-in Roll-out Deck Extension
- All Motion Alarm
- ECU Controlled Engine Speed
- Fold Down Rails
- Full Time Traction Control
- Horn
- Hourmeter
- LCD Display with LiftSense System
- Lubrication-Free Scissor Arm Bushings
- Manual Descent Pull Cable
- Nickel Plated Pins, Yellow Zinc-Chromate Plated Fasteners
- Oscillating Front Axle
- Pin-based Load Sensing System
- Pin-Less Fold Down Rail System
- Platform Control Box with LCD Display, USB Charger and Phone Holster
- Proportional Lift and Drive
- Remote Engine Oil Filter Package
- Scissor Maintenance Prop
- Self-Closing Gate
- Telematics-Ready Harness
- Tie Down Lugs

1. Hydraulic leveling jacks and QuikLevel Advanced cannot be outfitted on same machine.

ACCESSORIES & OPTIONS

- 2WD
- 2500W Generator 60Hz/110V (Belt-driven)
- 26 x 12 Foam-filled Non-Marking Tires
- 33.5-lb (15.2-kg) Aluminum Propane Tank
- ClearSky™
- Dual Flashing Amber Beacons - LED
- Dual LP Tanks (Dual Fuel Engines only)
- Dual LP Tank Brackets
- Flashing Amber Beacon - LED
- Heavy Duty Pipe Racks
- Hydraulic Leveling Jacks¹ (Auto Level)
- Hydraulic Oil Cooler
- Moveable, Removable Platform Control Box
- Operator Access Control
- QuikLevel Advanced¹
- Special Hydraulic Fluids
- Special Paint
- White Noise Backup Alarm

RT4769

ENGINE POWERED ROUGH TERRAIN SERIES

SCISSOR LIFT



DIMENSIONS

All dimensions are approximate

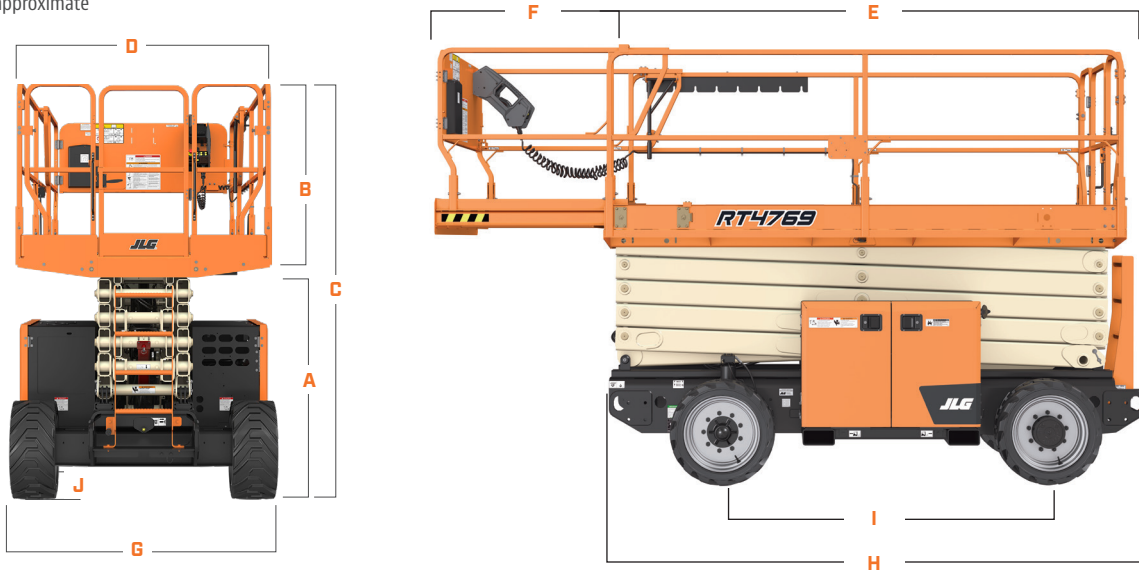

A. Platform Height (Lowered)	5-ft 4-in / 1.62-m	F. Platform Extension	42-in / 1.07-m
B. Platform Railing Height	44.7-in / 1.14-m	G. Machine Width	69.3-in / 1.76-m
C. Machine Height	109.1-in / 2.77-m	H. Machine Length	139-in / 3.53-m
D. Platform Width	63-in / 1.6-m	I. Wheelbase	81.3-in / 2.07-m
E. Platform Length	130.5-in / 3.3-m	J. Ground Clearance	9-in / 22-cm



(844) 432-4724

fairchildequipment.com



We provide coverage for one (1) full year, and cover all specified major structural components for five (5) years. Due to continuous product improvements, we reserve the right to make specification and/or equipment changes without prior notification. This machine meets or exceeds applicable ANSI and CSA requirements based on machine configuration as originally manufactured for intended applications. Please reference the serial number plate on the machine for additional information.



JLG INDUSTRIES, INC.
Toll-free US 877-JLG-LIFT
JLG.com

An Oshkosh Corporation Company