

# R1932

## ELECTRIC SCISSOR LIFT

SCISSOR LIFT



### KEY SPECS

**Platform Height**  
19-ft / 5.8-m

**Platform Capacity**  
507-lb / 230-kg

**Number of Occupants**  
Indoor: 2  
Outdoor: 1

**Stowed Drive Speed**  
2.1 mph / 3.4 km/h

### KEY FEATURES

- Available as an indoor-only option (R1932i) that is one of the lightest 19-ft scissor in its category.
- Active pothole protection provides increased ground clearance to tackle demanding terrain.
- Utilizes fewer parts with an improved battery charger for greater serviceability.
- Equipped with an all-steel platform and component doors with thicker rubber tires for added durability.

### ACCESSORIES & OPTIONS

- 4 x 6V AGM Batteries, 220 ah
- 900W Inverter
- Anti-Vandalism Package
- CAN-Enabled Charger
- Coiled Platform Control Box Cable
- Drive Motor Covers
- Dual Flashing Amber Beacons - LED
- MDI (Ground)
- Panel Carrier
- Pipe Racks
- QuikAccess Platform
- QuikFold Rails
- SkySense® Enhanced Detection System
- USB Charger & Phone Holder
- Workstation
- White Noise Alarm

### STANDARD SPECIFICATIONS

Performance	Indoor	Outdoor
Platform Height (Elevated)	19-ft / 5.8-m	19-ft / 5.8-m
Platform Capacity	507-lb / 230-kg	507-lb / 230-kg
Capacity on Platform Extension	265-lb / 120-kg	265-lb / 120-kg
Number of Occupants	2	1
Lift / Lower Time (No Load)	20/27 seconds	20/27 seconds
Lift / Lower Time (Rated Load)	25/26 seconds	25/26 seconds
Maximum Drive Height	Fully Elevated	Fully Elevated
Weight*	3,450-lb / 1,564-kg	3,450-lb / 1,564-kg
Max. Ground Bearing Pressure	114 psi / 8.0 kg/cm <sup>2</sup>	114 psi / 8.0 kg/cm <sup>2</sup>
Drive Speed (Lowered)	2.1 mph / 3.4 km/h	2.1 mph / 3.4 km/h
Drive Speed (Raised)	0.5 mph / 0.8 km/h	0.5 mph / 0.8 km/h
Gradeability	25%	25%
Max Tilt Rating (Side-to-Side)	1.75 Degrees	1.50 Degrees
Max Tilt Rating (Fore and Aft)	3.75 Degrees	3.75 Degrees
Turning Radius (Inside)	Zero	Zero
Turning Radius (Outside)	66-in / 1.68-m	66-in / 1.68-m

\*Certain options or country standards increase weight

### Power

Batteries	4 x 6V 220 amp-hr
Charger	27 Amp
Drive	Hydraulic Front Wheel

### Tires

Standard	12.7 x 4-in / 323 x 100-mm
----------	----------------------------

### Brakes

Multi-Disc Friction

### Hydraulic System

Capacity	4 gal / 15 L
Pump	Fixed Displacement Gear

### STANDARD FEATURES

- 27 amp Multi-Function Universal Charger
- AC Receptacle in Platform
- Active Pothole Protection System
- All Motion Alarm
- Analyzer Port for Diagnostics
- Battery Condition Indicator
- ClearSky Smart Fleet™ Hardware (CS550)\*\*
- Diamond Tread Steel Deck
- Dynamic Braking
- Foot-Actuated Deck Extension
- Fork Lift Pockets
- Greaseless Kingpin Joints
- Horn
- Hourmeter
- Lanyard Attach Points
- LED Motion/Amber Beacon (CS550)\*\*
- Lifting and Tie Down Points
- Load Sensing System
- Lubrication Free Scissor Arm Bushings
- Manual Descent Cable
- Movable, Removable Platform Control
- Nickel Plated Pins
- Proportional Controls
- Removable Ladder
- Scissor Maintenance Prop
- Self-Closing Gate
- Steel Swing-Out Doors
- Tilt Alarm and Light
- Variable Tilt Visual Zone Indicator

\*\*Standard beacon and ClearSky Smart Fleet hardware availability varies by model throughout 2023.

# R1932

ELECTRIC SCISSOR LIFT

SCISSOR LIFT



## DIMENSIONS

All dimensions are approximate

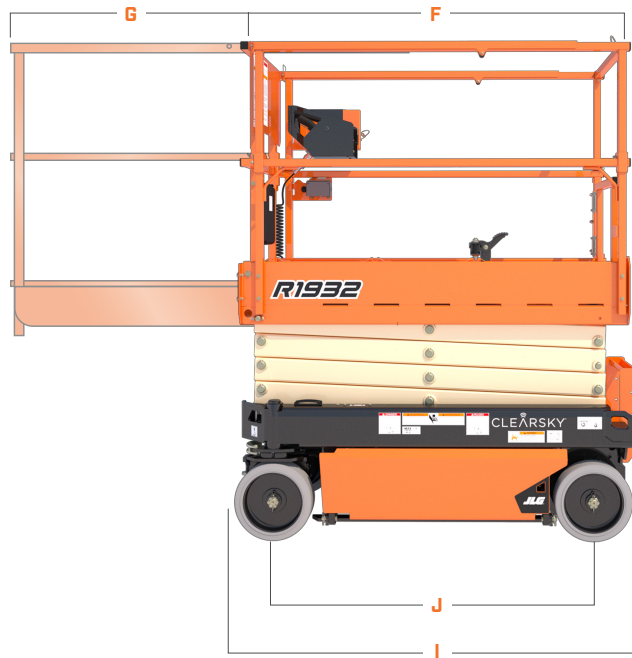
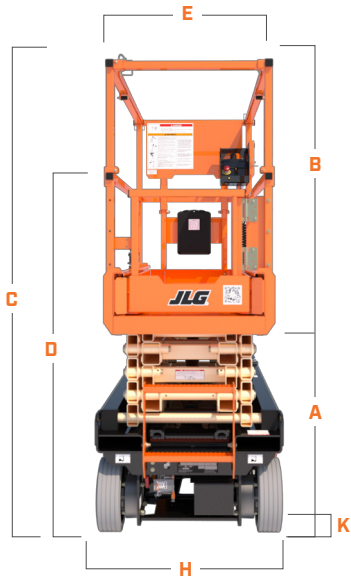

- A.** Platform Height (Lowered) 38.6-in / .981-m
- B.** Platform Railing Height 43.3-in / 11-m
- C.** Machine Height (Rails Raised) 82.8-in / 21-m
- D.** Machine Height (Rails Lowered) 64.3-in / 1.63-m
- E.** Platform Width 25.4-in / .64-m
- F.** Platform Length 62.7-in / 1.59-m
- G.** Platform Extension 36-in / 91-cm

- H.** Machine Width 32-in / 81-cm
- I.** Machine Length 68.7-in / 1.74-m
- J.** Wheelbase 53-in / 1.34-m
- K.** Ground Clearance 2.8-in / 7-cm



(844) 432-4724

[fairchildequipment.com](http://fairchildequipment.com)



We provide coverage for one (1) full year, and cover all specified major structural components for five (5) years. Due to continuous product improvements, we reserve the right to make specification and/or equipment changes without prior notification. This machine meets or exceeds applicable ANSI and CSA requirements based on machine configuration as originally manufactured for intended applications. Please reference the serial number plate on the machine for additional information.



JLG INDUSTRIES, INC.  
Toll-free US 877-JLG-LIFT  
JLG.com

An Oshkosh Corporation Company