

E18MML

DRIVEABLE VERTICAL LIFT

VERTICAL LIFT



KEY SPECS

Platform Height
18-ft / 5.5-m

**Platform Capacity
[Standard Platform]**
450-lb / 204-kg

Turning Radius
Zero

Stowed Drive Speed
2.5 mph / 4 km/h

KEY FEATURES

- Designed with the operator in mind, featuring familiar controls, Point & Go steer, ergonomic joystick and ease of entry/exit from platform.
- Lightweight and compact footprint is ideal for sensitive flooring and accessing tight spaces with high transportability.
- Increase productivity with longer running batteries and optional extensions, trays and platforms.
- Quick access to key, known scissor components and durable mast protection offers efficient serviceability while the multi-display indicator provides real-time fault code and maintenance information to maximize uptime.

ACCESSORIES & OPTIONS

- Anti-Vandalism Package
- CleanGuard™
- ClearSky™ Telematics
- Crane Hook
- Dual Amber Beacon
- Floor Mat
- Front and Side Bumpers
- USB Charger & Phone Cradle
- Stock Picker (E18MSP) Package²

*Certain options or country standards increase weight.

1. Average range, refer to Operations Manual.

2. Includes standard 28 x 29.5-in fold-down work tray platform with side entry saloon doors with gate alarm, dual amber beacons and floor mat.

3. If choosing a platform option, the machine will ship with the selected platform. If choosing the spare platform, the machine will ship with first selected platform, plus the spare platform. If no platform is selected, the standard platform will ship.

STANDARD SPECIFICATIONS

Performance	Indoor ONLY
Platform Height (Elevated)	18-ft / 5.5-m
Working Height	24-ft / 7.5-m
Platform Capacity	400-lb / 181-kg
Work Tray Capacity	100-lb / 45-kg
Number of Occupants	1
Lift / Lower Time ¹	23/23 seconds
Maximum Drive Height	Fully Elevated
Weight*	1,950-lb / 885-kg
Ground Bearing Pressure	TBD
Drive Speed (Elevated)	0.5 mph / .8 km/h
Drive Speed (Lowered)	2.5 mph / 4 km/h
Gradeability	30%
Turning Radius (Inside)	Zero
Turning Radius (Outside)	48-in / 1.2-m

Power Source

Battery	Four 6V - 220 AH (2X More Duty Cycles Over Competition)
Charger	27 amp
Drive	4 Brush Direct Electric Drive (Planetary Gear)

Lift & Steer Systems

Lift	Hydraulic
Steer	Point & Go

Tires

Front / Rear	8-in Casters / 10 x 3-in Non-Marking
--------------	--------------------------------------

Brakes

Electric	
----------	--

STANDARD FEATURES

- 27 amp Multi-Function Universal Charger
- 28 x 29.5-in Fold-Down Work Tray Platform with Side Entry Saloon Doors
- AC Receptacle in Platform
- Active Pothole Protection System
- All Motion Alarm
- Analyzer Port for Diagnostics
- Battery Condition Indicator
- DC Electric Drive
- Dynamic Braking
- Electric Brake Release
- Fork Lift Pockets
- Greaseless Kingpin Joints
- Horn
- Hourmeter
- Lanyard Attach Points
- Lifting and Tie Down Points
- Load Sensing System
- Manual Descent
- Mast Maintenance Prop
- Movable, Removable Platform Control with 6-ft Coiled Cable
- Multi-Display Indicator
- Proportional Controls
- Tilt Alarm and Light
- Telematics Ready

QUICK CHANGE PLATFORM OPTIONS

- 26.9 x 26-in Platform
 - 26.9 x 26-in Platform
 - Platform Capacity, 450-lb
 - Front Entry, Drop Bar
- Narrow Platform
 - 22 x 26-in
 - Platform Capacity, 450-lb
 - Front Entry, Drop Bar
 - Also Available as Spare Platform³
- Front Entry Extension Platform
 - 29.5 x 51-in
 - Platform Capacity, 400-lb
 - Extension Capacity, 250-lb
 - Platform Entry Styles
 - Front Entry Saloon Doors
 - Front Entry Drop Bar
- Fold-Down Work Tray Platform
 - 28 x 29.5-in
 - Platform Capacity, 400-lb
 - Tray Capacity, 100-lb
 - Platform Entry Styles
 - Side Entry Saloon Doors
 - Side Entry Drop Bar
 - Aluminum Tray with Side Entry Saloon Doors

E18MML

DRIVEABLE VERTICAL LIFT

VERTICAL LIFT



DIMENSIONS

All dimensions are approximate

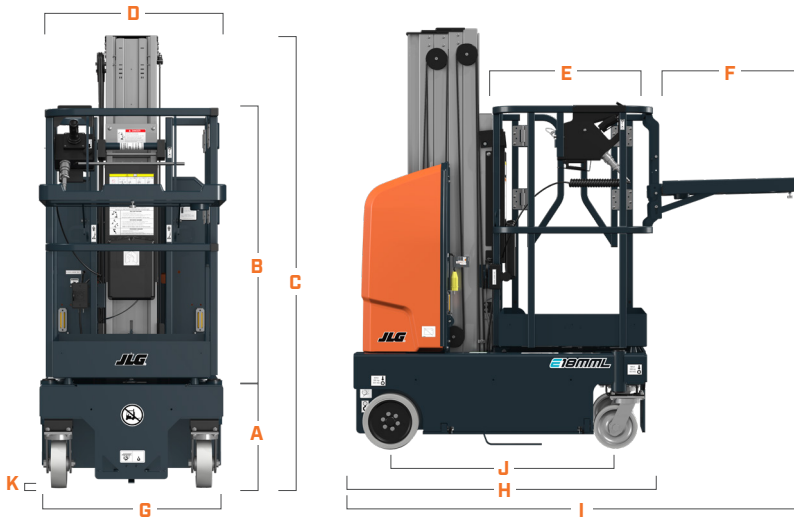

A. Platform Entry Height	18.5-in / 47-cm
B. Platform Rail Height	43.8-in / 1.11-m
C. Machine Height	78-in / 1.98-m
D. Platform Width	28-in / 71-cm
E. Platform Length	29.5-in / 75-cm
F. Platform Tray	25-in / 63-cm
G. Machine Width	30-in / 76-cm
H. Machine Length - Retracted Tray	57.6-in / 1.46-m
I. Machine Length - Extended Tray	81-in / 2.06-m
J. Wheelbase	41.4-in / 1.05-m
K. Ground Clearance	2.5-in / 6.35-cm



(844) 432-4724

fairchildequipment.com



We provide coverage for one (1) full year, and cover all specified major structural components for five (5) years. Due to continuous product improvements, we reserve the right to make specification and/or equipment changes without prior notification. This machine meets or exceeds applicable ANSI and CSA requirements based on machine configuration as originally manufactured for intended applications. Please reference the serial number plate on the machine for additional information.



JLG INDUSTRIES, INC.
Toll-free US 877-JLG-LIFT
JLG.com

An Oshkosh Corporation Company