



## STANDARD SPECIFICATIONS

### Performance

Platform Height	26-ft 6-in / 8.10-m
Horizontal Outreach	8-ft 8-in / 2.64-m
Up and Over Height	21-ft 4-in / 6.51-m
Swing	345 Degrees Non-continuous
Platform Capacity	500-lb / 227-kg
Platform Size	28 x 36-in / 70 x 90-cm
Weight*	6,900-lb / 3,130-kg
Ground Bearing Pressure	319 psi / 22.4 kg/cm <sup>2</sup>
Ground Clearance	3.9-in / 10-cm
Drive Speed (Stowed)	3.4 mph / 5.5 km/h
Drive Speed (Elevated)	0.47 - .25 mph <sup>1</sup> / 0.76 - .41 km/h
Gradeability	25%
Turning Radius (Inside)	1-ft 8-in / 0.55-m
Turning Radius (Outside)	6-ft 5-in / 1.99-m

\*Certain options or country standards increase weight

<sup>1</sup> .47 mph up to 23-ft 7.5-in platform height (with jib fully raised) / .25 mph above 23-ft 7.5-in platform height (with jib fully raised)

### Power Source

Batteries	24V DC, 260 amp-hr AGM
Charger	27 amps

### Brakes

Spring Applied Disc

### Tires

125 x 406 Non-Marking

### KEY SPECS

**Platform Height**  
26-ft 6-in / 8.10-m

**Up and Over Reach**  
21-ft 4-in / 6.51-m

**Horizontal Outreach**  
8-ft 8-in / 2.64-m

**Platform Capacity**  
500-lb / 227-kg

### KEY FEATURES

- Reach up and over obstacles in tight spaces with a vertical telescopic mast with a jib.
- Equipped for indoor jobs with standard non-marking tires and efficient electric power, and for outdoor work with 25% gradeability.
- Unmatched positioning capabilities with a 345 degree rotating mast.
- Optimum battery life and more duty cycles with AC direct electric drive.

## STANDARD FEATURES

- 110V-AC Receptacle in the Platform
- 345 Degree Non-continuous Swing
- 5 Degree Tilt Alarm/Indicator Light
- All Motion Alarm
- Battery Condition Indicator
- Emergency Lowering Pump
- Horn
- Hourmeter
- Lifting Eyes
- Load Sensing System
- Proportional Controls
- Platform, Saloon Gate
- SkyGuard SkyLine™
- Tie-down Lugs
- Warning Beacon

## ACCESSORIES & OPTIONS

- 1/2-in Airline
- 70W Platform Work Light
- ClearSky™ Legacy Telematics
- Platform, Drop Bar

## DIMENSIONS

All dimensions are approximate

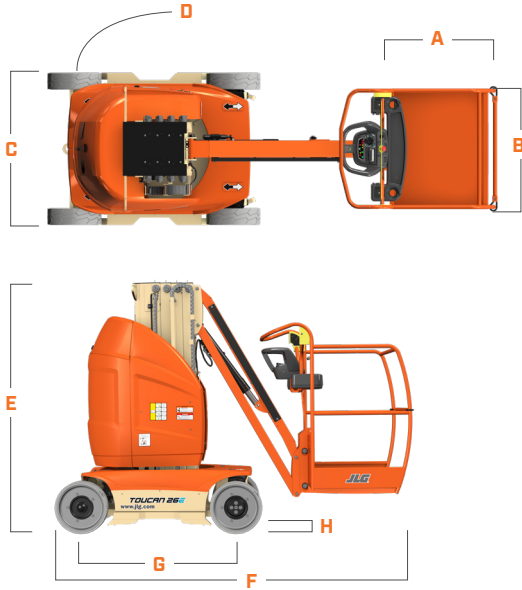

- A.** Platform Width      36-in / 0.90-m
- B.** Platform Length    28-in / 0.70-m
- C.** Machine Width       3-ft 3-in / 0.99-m
- D.** Tailswing             4.7-in / 12-cm
- E.** Machine Height      6-ft 5-in / 1.99-m
- F.** Machine Length     9-ft 3-in / 2.82-m (Drop Bar)
- G.** Wheelbase            3-ft 9-in / 1.20-m
- H.** Ground Clearance    3.9-in / 10-cm



(844) 432-4724

[fairchildequipment.com](http://fairchildequipment.com)



We provide coverage for one (1) full year, and cover all specified major structural components for five (5) years. Due to continuous product improvements, we reserve the right to make specification and/or equipment changes without prior notification. This machine meets or exceeds applicable ANSI and CSA requirements based on machine configuration as originally manufactured for intended applications. Please reference the serial number plate on the machine for additional information.

## REACH DIAGRAM

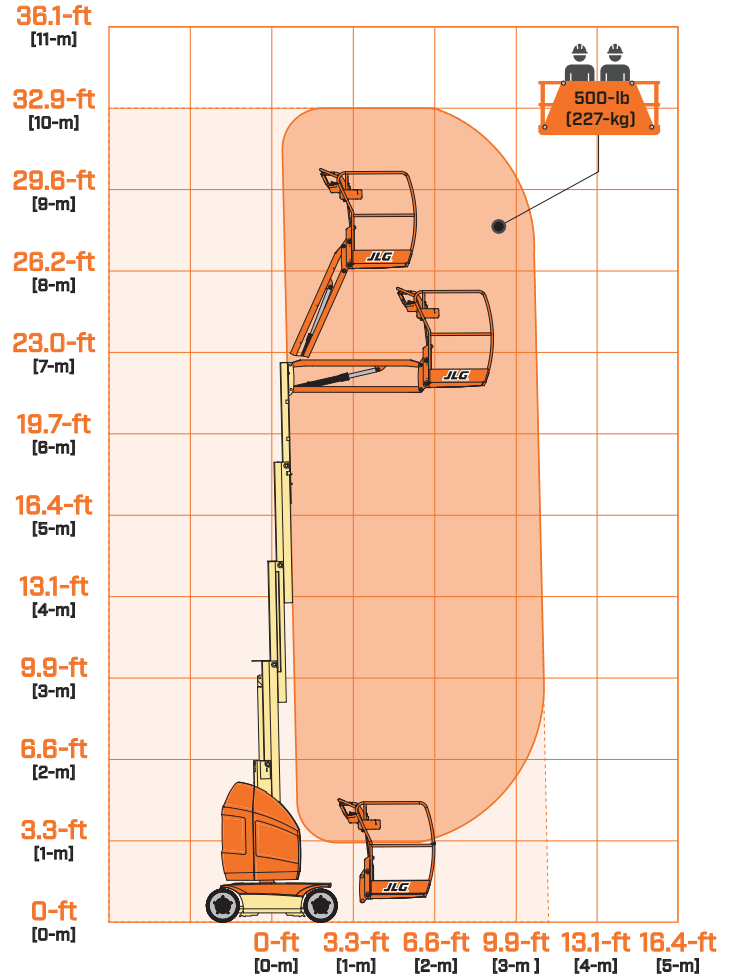

**JLG INDUSTRIES, INC.**  
 Toll-free US 877-JLG-LIFT  
**JLG.com**  
 An Oshkosh Corporation Company