



+ TASK **SIDEWINDER® F-165** TASK SUPPORT VEHICLE

TASK **SIDEWINDER® F-165**

SIDEWINDER® F-165.

The SIDEWINDER® F-165 is the new innovative stock picker by TASK® Forklifts. The unit uses tried and tested technology to create one the safest, easiest to use, innovative stock pickers on the market.

With a reverse camera, optional USB ports, a real time Curtis control display, standard Class 2 carriage forks, and a range of accessories to choose from, the SIDEWINDER® F-165 is the all one machine needed in your warehouse.

INDUSTRY READY.

The SIDEWINDER® includes an industrial battery allowing operators multiple shift use before needing to be recharged. The inbuilt charger allows users to charge the machine via a standard 110V wall plug.

The Class 2 carriage forks, and stainless steel goods tray/ platform can carry up to 880lbs allowing operators to carry more stock at once.



DIMENSIONS.

The SIDEWINDER® Task Support Vehicle can work in aisles as narrow as 33" (Under 3ft); and has a total dimension of 68 ½" x 33".



**SUPPORT
VEHICLE**

WEB: FAIRCHILDEQUIPMENT.COM **CALL US:** (844) 432-4724
EMAIL: INFO@FAIRCHILDEQUIPMENT.COM





165"
Lift Height



880lbs
Capacity



Order
Picker



Built-In 110v
Charger

TECHNICAL INFO

DESCRIPTION	SPECIFICATION (F SERIES)
A. Load Capacity - including operator (lbs)	880 lbs
B. Lift Height (inches)	165"
B1. Fork Lift Height (inches)	25"
C. Extended Height (inches)	239.5"
D. Collapsed Height (inches)	77.25"
E. Overall Length Chassis - No Tray or Tines (inches)	56.25"
F. Overall Width (inches)	33"
G. Wheelbase (inches)	45"
H. Ground Clearance (inches)	3.25"
I. Load Tray Height (inches)	44.5"
J. Tray Length (inches)	12.25"
K. Control Panel Height (inches)	33.5"
L. Operator Position Height (inches)	10"
M. Wheel Size - Drive (inches)	10" x 3"
N. Wheel Size - Load (inches)	6" x 3"
O. Weight - Less Battery (lbs)	2651 lbs
P. Carriage Width (inches)	24"
Q. Right Angle Stacking Aisle (inches)	Dimension E + Load Length + 4"

TASKSIDEWINDER® F-165

SUPPORT
VEHICLE

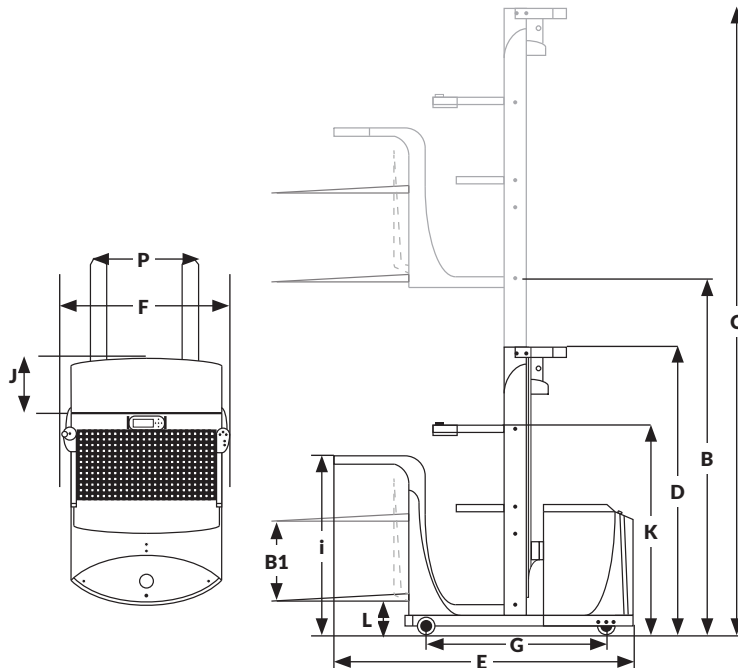

SIDEWINDER® F-165
Technical Drawing

Due to continuous product improvement, specifications are subject to change without notice or obligation. Some systems and features shown are optional at extra cost.

WEB: FAIRCHILDEQUIPMENT.COM CALL US: (844) 432-4724

EMAIL: INFO@FAIRCHILDEQUIPMENT.COM

