

Genie® S®-80 HF & S-85 HF

Specifications

Models	S-80 HF		S-85 HF	
Measurements	US	Metric	US	Metric
Working height max. ⁽¹⁾	86 ft	26.38 m	91 ft	27.91 m
Platform height max.	80 ft	24.38 m	85 ft	25.91 m
Horizontal reach max.	68 ft 6 in	20.88 m	72 ft 6 in	22.10 m
Below ground reach	5 ft 6 in	1.68 m	8 ft 8 in	2.64 m
A Platform length (8 ft/6 ft)	3 ft/2 ft 6 in	0.91 m/0.76 m	3 ft/2 ft 6 in	0.91 m/0.76 m
B Platform width (8 ft/6 ft)	8 ft/6 ft	2.44 m/1.83 m	8 ft/6 ft	2.44 m/1.83 m
C Height - stowed (tires)	9 ft 2 in	2.80 m	9 ft 2 in	2.80 m
D Length - stowed (tires)	37 ft 7 in	11.23 m	40 ft 7 in	12.37 m
Length - storage/transport (jib tucked under)	-	-	33 ft 8 in	10.25 m
E Width (tires)	8 ft 6 in	2.59 m	8 ft 6 in	2.59 m
F Wheelbase	9 ft 4 in	2.85 m	9 ft 4 in	2.85 m
G Ground clearance - center (tires)	15.8 in	0.40 m	15.8 in	0.40 m
H Height under counterweight	3 ft 7 in	1.09 m	3 ft 7 in	1.09 m

Productivity

Lift capacity max. - unrestricted	600 lb	272 kg	600 lb	272 kg
Lift capacity max. - restricted	1,000 lb	454 kg	1,000 lb	454 kg
Number of Platform Occupants	2	2	2	2
Platform rotation	160°	160°	160°	160°
Jib length	—	—	5 ft	1.52 m
Vertical jib rotation (up/down)	—	—	133°	133°
Turntable rotation	360°	360°	360°	360°
Turntable tailswing	5 ft 3 in	1.6 m	5 ft 3 in	1.6 m
Drive speed - stowed (tires)	3.0 mph	4.8 km/h	3.0 mph	4.8 km/h
Drive speed - raised (tires)	0.5 mph	0.2 m/s	0.5 mph	0.2 m/s
Gradeability - stowed ⁽²⁾	45 %	45 %	45 %	45 %
Tilt sensor activation (front to back/side to side)	7°/5°	7°/5°	7°/5°	7°/5°
Turning radius - inside/outside (tires)	12 ft/21 ft 6 in	3.66 m/6.55 m	12 ft/21 ft 6 in	3.66 m/6.55 m
Tires	41/18LL22.5	41/18LL22.5	41/18LL22.5	41/18LL22.5

Power

Power	Diesel	Diesel	Diesel	Diesel
Hydraulic tank capacity	40 gal	150 L	40 gal	150 L
Fuel tank capacity	35 gal	132 L	35 gal	132 L

Weight⁽³⁾ and Floor Loading⁽⁴⁾

Weight (tires)	35,500 lb	16,103 kg	38,000 lb	17,237 kg
Tire contact pressure	100 psi	689.47 kPa	100 psi	689.47 kPa
Occupied floor pressure (tires)	343 psf	16.42 kPa	366 psf	17.53 kPa

Sound and Vibration Levels

Sound Pressure level (ground workstation)	85 dBA	85 dBA	85 dBA	85 dBA
Sound Pressure level (platform workstation)	78 dBA	78 dBA	78 dBA	78 dBA
Vibrations	< 2.5 m/s ²	< 2.5 m/s ²	< 2.5 m/s ²	< 2.5 m/s ²

(1) The metric equivalent of working height adds 2m to platform height. The imperial equivalent adds 6ft to platform height.
 (2) Gradeability applies to driving on slopes and may vary depending on options and machine configurations. See operator's manual for details regarding slope ratings.
 (3) Weight refers to standard configuration and may vary depending on options and/or country standards.
 (4) Floor loading information is approximate and may vary depending on options and machine configurations. It should be used only with adequate safety factors.

Range of motion S-80 HF

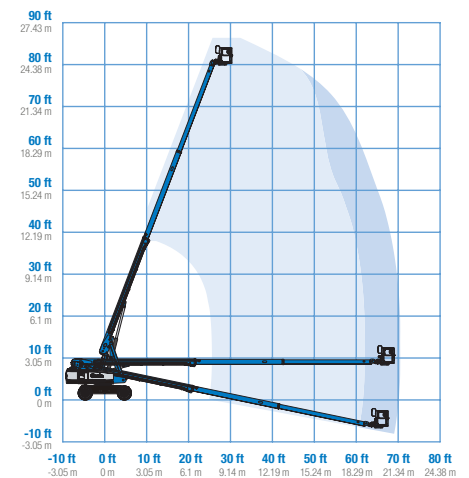

Range of motion S-85 HF

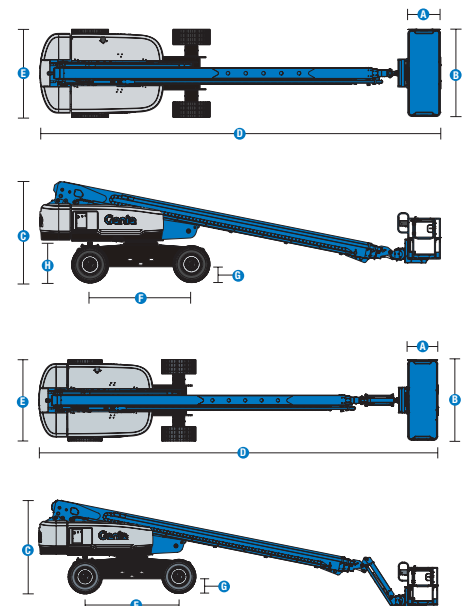
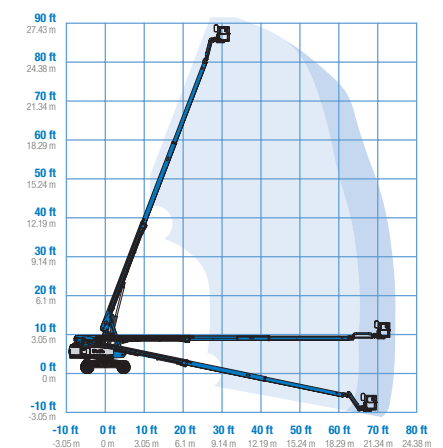

Genie® S® -80 HF & S-85 HF

SKU: Standard Model

- S-80 HF, 4WD*

SKU: Standard Model

- S-85 HF, 4WD*

* Build to Order

Option availability		S	S+	BtO
Power	70 hp, 52 kW, GM Vortec 3.0L, Gas/LPG			<input type="radio"/>
	74 hp, 55 kW, Deutz TD2.9L, Turbo Diesel, T4f (TRAX and 80/85)			<input type="radio"/>
	Cold weather package			<input type="radio"/>
	Diesel air intake pre-cleaner			<input type="radio"/>
	Anti-restart engine protection			<input checked="" type="checkbox"/>
	Auto engine fault shutdown			<input checked="" type="checkbox"/>
	In cylinder glow plug (diesel only)			<input checked="" type="checkbox"/>
Platform	6ft/1.83m dual-entry platform with side swing gate			<input type="radio"/>
	8ft/2.44m tri-entry platform with side swing gate			<input checked="" type="checkbox"/>
	6ft/1.83m Aircraft protection platform with sliding mid-rail			<input type="radio"/>
	6ft/1.83m Aircraft protection platform with side swing gate			<input type="radio"/>
	Dual axis joystick steering			<input checked="" type="checkbox"/>
	Thumb rocker steering			<input type="radio"/>
	Air line to platform			<input type="radio"/>
	Control box covers			<input type="radio"/>
	Lift Guard Full Mesh panels			<input type="radio"/>
	Lift Guard Half Mesh panels			<input type="radio"/>
	Light Package: drive and work lights			<input type="radio"/>
	Platform auxiliary top rail			<input type="radio"/>
	Lift Power 3kW AC Generator, 110V/60Hz			<input type="radio"/>
	Lift Power 3kW AC Generator, 220V/50Hz			<input type="radio"/>
	Lift Power 12kW Welder Ready			<input type="radio"/>
	600lb/300kg unrestricted platform capacity			<input checked="" type="checkbox"/>
	Drive enable system			<input checked="" type="checkbox"/>
	Horn			<input checked="" type="checkbox"/>
	Lift Guard Contact Alarm			<input checked="" type="checkbox"/>
	Lift Tools Work Tray			<input checked="" type="checkbox"/>
Platform load sense system			<input checked="" type="checkbox"/>	
Proportional controls			<input checked="" type="checkbox"/>	
Self-leveling platform			<input checked="" type="checkbox"/>	
Chassis	Lift Connect Telematics			<input checked="" type="checkbox"/>
	Lift Connect with Access Manager upgrade			<input type="radio"/>
	Biodegradable hydraulic oil			<input type="radio"/>
	Cold weather hydraulic oil			<input type="radio"/>
	Fire resistant hydraulic oil			<input type="radio"/>
	High floatation, air-filled tires			<input type="radio"/>
	Deluxe hostile environment kit			<input type="radio"/>
	Hostile environment kit			<input type="radio"/>
	Positive air shutdown system			<input type="radio"/>
	LPG tank 33.5lb			<input type="radio"/>
	Tow package			<input type="radio"/>
	Active oscillating axle			<input checked="" type="checkbox"/>
	Alarm package: includes flashing beacon and travel alarm			<input checked="" type="checkbox"/>
	Descent, tilt and motion alarm			<input checked="" type="checkbox"/>
	Dual battery system			<input checked="" type="checkbox"/>
	Hour meter			<input checked="" type="checkbox"/>
	Hydraulic oil cooler			<input checked="" type="checkbox"/>
Tech Pro Link connector			<input checked="" type="checkbox"/>	
Wheel motors 2 speed			<input checked="" type="checkbox"/>	

Positive air shutdown system for Deutz engines only

- S Standard
- S+ Standard +
- BtO Build to Order
- Standard Features
- Options



Sensitive Terrains



Dual Capacity



Lift Power



Genie Genuine Accessories⁽¹⁾

- Lift Tools Productivity Tools
- Lift Connect Telematics
- Tech Pro Link Handheld Device

(1) More accessories available from Genie Genuine Parts.

Product specifications are subject to change without notice or obligation. Photographs and/or drawings herein are for illustrative purposes only. Refer to the appropriate Operator's Manual for instructions on proper equipment use. Failure to follow instructions in the Operator's Manual may result in serious injury or death. The only warranty applicable to our equipment is the standard written warranty applicable to the particular product and sale and we make no other warranty, express or implied. Products and services listed may be trademarks, service marks or trade names of Terex Corporation and/or their subsidiaries in the USA and many other countries. Terex, Genie, Quality By Design, Xtra Capacity, Lift Power, Lift Guard, Lift Tools, Lift Connect and Tech Pro Link are registered trademarks of Terex Corporation or its subsidiaries.

03/22

