

Powered Drive Straddle Truck **BLUE GIANT**[®]

BGS-30

Short turning radius makes it an excellent choice for narrow aisles, tool rooms or street level loading.

CAPACITY

- 3000 lb (1360 kg) at 24" (610 mm) load center

BATTERY

- 24-volt 224AH AGM maintenance-free battery pack with built-in 110 VAC charger
- Minimum battery weight: 480 lb (218 kg)
- Compartment dimensions (open): 26.4" x 9.1" (670 x 231 mm)
- Connector: Anderson 175 Gray—A-11

SPEED

- **EMPTY:** 0 - 3.4 mph (5.5 kph)
- **LOADED:** 0 - 3.1 mph (5 kph)

- **LIFT - EMPTY:** up to 31 fpm
- **LIFT - LOADED:** up to 23 fpm with 3000 lb (1360 kg) load

- **LOWERING - EMPTY:** up to 25 fpm
- **LOWERING - LOADED:** up to 33 fpm with 3000 lb (1360 kg) load

TIRES / WHEELS

- **DRIVE:** 9" x 3" (229 x 76 mm) polyurethane
- **DUAL LOAD:** (2) 4" x 2.9" (102 x 74 mm) polyurethane

HYDRAULICS

- Lift cylinder with hard chrome-plated rods
- Pump unit including motor, gear pump, solenoid, and pressure compensated lowering valves

ELECTRICAL

- 24-volt ZAPI AC-0 inverter with matching drive motor provides high performance throughout the entire speed range
- Separately fused power control circuits
- Quick disconnect EPD power cutoff
- Hour meter / battery discharge indicator combo
- Power configurations and diagnostic features are displayed with a ZAPI handheld console
- Lower battery interrupt
- Travel speed remains constant relative to throttle position, regardless of load

BRAKES

- Regenerative electromagnetic brake mounted on motor armature shaft, multiplying braking power through the transmission
- Brake is applied when control arm is in the vertical or horizontal handle position
- Neutral braking resists rollback on ramps



OPERATION / CONTROLS

- Ergonomic operator handle with travel, lift, and lower functions
- Angle grips allow easy operation with either hand
- Wrap-around guard
- Reversing switch
- Thumb control and horn
- Top mounted tiller arm offers excellent operator comfort and minimum steering effort
- Gas-assisted spring handle
- Creep speed function with steer handle at 5° back-tilt from vertical

TRANSMISSION

- Vertically mounted drive motor direct mounted to gear housing
- Oil-bathed ZF GK10 hypoid bevel gear drivetrain
- State-of-the-art optimized gear technology provides minimal envelope circle, zero maintenance, and low noise level

FRAME AND MAST

- Bolt-on high-visibility mast, I-beam construction and lift cylinders positioned on the outer I-beam for best view through mast
- 4" (102 mm) wide adjustable straddle legs
- Straddle leg inside dimension (ID) can be set at 42" (1067 mm) to 50" (1270 mm) in 4" (102 mm) increments; 42" (1067 mm) to 50" (1270 mm) with the triple stage mast.
- Class II ITA fork carriage with 36" (914 mm) tall load backrest
- Forks are adjustable from 8" (203 mm) ID to 31" (787 mm) OD
- Dual lift chains

BEARINGS

- **DRIVE WHEEL:** tapered roller bearings sealed in oil bath
- **LOAD WHEELS:** sealed in ball bearings

ACCESSIBILITY

- Removal of two piece power head cover exposes major components for inspection and maintenance

OPTIONAL EQUIPMENT

- 48" (1219 mm) tall load backrest
- Cold conditioning
- Side-shifting fork carriage
- 24V industrial battery 255 AH / 5.9 kWh

Right Angle Stacking Aisle Dimensions

Load Length	Load Width		
	36"	40"	48"
36"	67.6"	67.6"	67.6"
40"	69.1"	69.1"	69.1"
48"	73.4"	73.4"	73.4"

For ease of use add 8" to aisle dimension listed. If sideshift option is used add 2".

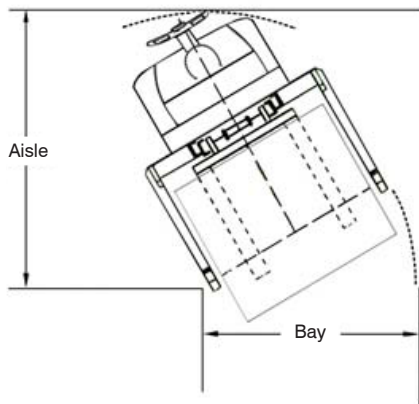

Note: Aisle dimensions listed above assume the bay width to be straddled OD plus 2" (1" on either side of straddle leg). Straddle OD is the load width plus 8". *For metric conversion multiply inches by 25.4.

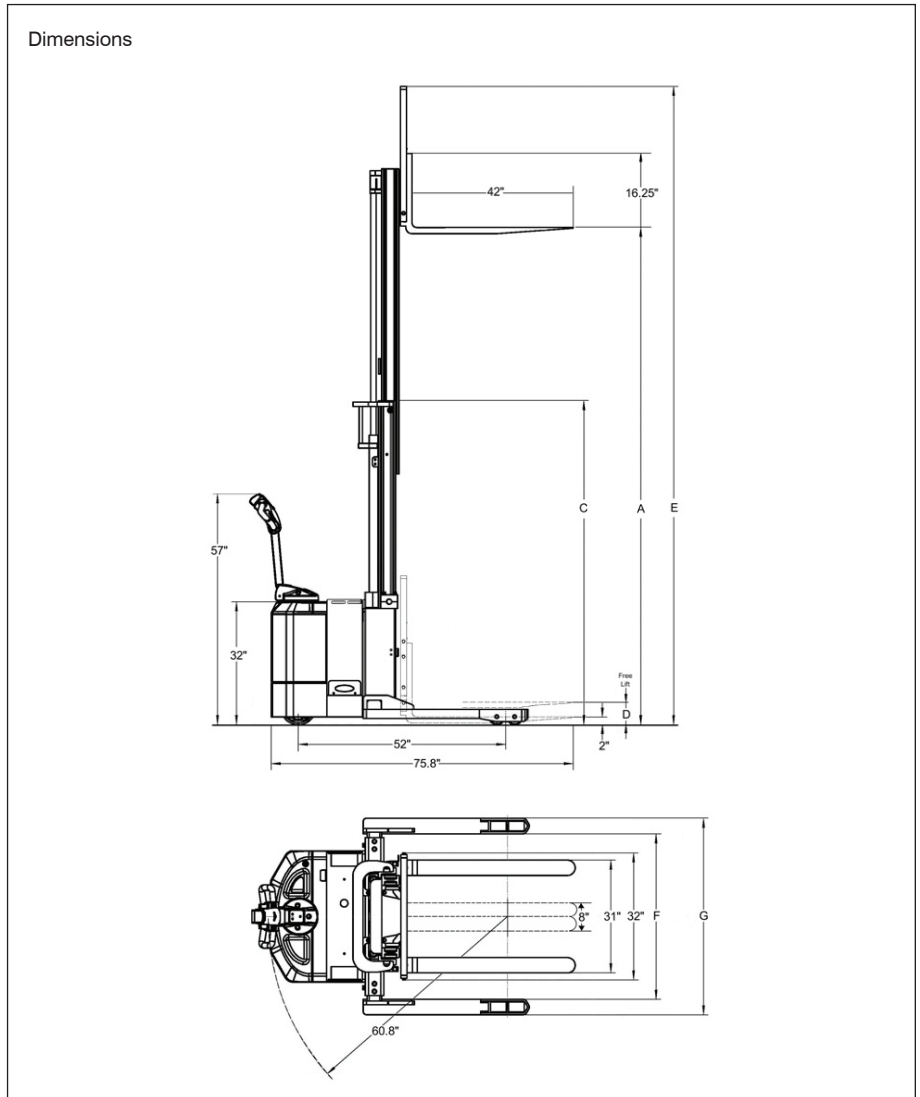

Model#	Mast	Lift Height	Col Height	Free Lift	Ext Height w/LBR	² Adjustable Straddle Leg (4" Increments)		³ Weight Chassis Only
		A	C	D	E	ID	OD	
		F		G				

3000 Capacity @ 24" Load Center ITA Class II Fork Carriage

Model#	Mast	Lift Height	Col Height	Free Lift	Ext Height	Straddle Leg		Weight
BGS-30-104	Telescopic	104"	71"	6"	142"	42 to 50"	50 to 58"	2042 lb
BGS-30-126		126"	83"		165"			2172 lb
BGS-30-157	Trimast	157"	71"	50"	193"			2444 lb
BGS-30-177		177"	79"	58"	213"			2539 lb

¹ Derates 1000 lb above 162"
² Minimum inside dimension (ID) 38". Outside dimension = inside dimension + 8"
³ Estimated shipping weight without battery