

# Lithium Pallet Truck

Only available in Canada

**BLUE GIANT**®

## LPJ-44

The safer and more efficient solution for your material handling needs.

### CAPACITY

- 4400 lb (1995 kg)

### BATTERY

- 48V/30 AH rechargeable lithium ion battery
- Revolutionary Easy Exchange HD Battery delivers up to 3.5 hours of operation and can be fully charged within 2 hours. Optional extra batteries can be purchased to extend run time or to serve as a reliable back-up.

### CHARGER

- Built-in 110VAC 13.5A plug-in internal charger

### WEIGHT

- 550 lb with battery

### FORKS

- 27" OAW x 46" OAL

Designed for use with standard 48" pallets and other common skids and containers. Forks can achieve a maximum elevation of over 8.5" and are built for heavy duty use and come standard with a robust fork entry roller for reliable pallet entry.

### PERFORMANCE

- 48-volt curtis travel control with permanent magnet drive motor.
- Variable speed from 0 mph to 3.7 mph empty
- Variable speed from 0 mph to 3.3 mph loaded

### WHEELS

- Drive (1) 9.6" x 3.7" polyurethane
- Load (2) 3.25" x 4.5" polyurethane

### BRAKES

Electromechanical brake provides good stopping power when handle is upright or lowered beyond the operating range.

### CONTROLS

Travel, lift, and lower functions are located on the ergonomic control head. All operator controls are accessible without having to lift one's hand from the handle grips. The control head is designed to allow for easy operation of with either hand and includes a belly button reversing switch, dual butterfly travel controls, horn, and battery discharge indicator and key switch. The low mounted tiller arm offers excellent operator comfort and minimum steering effort.



### HYDRAULICS

DC pump and chrome plated cylinder provide for smooth and efficient lifting.

### ELECTRICAL

Water resistant connectors and shrouded wiring harness supply power reliably to components. System includes an emergency power disconnect and covered on-board dock for the Easy Exchange HD Battery.

### SERVICEABILITY

Removable covers and modular design of components provides for easy maintenance with simple hand tools. Two piece drive wheel reduces complexity of tire changes.

### OPTIONS

- 48" load back rest
- Traction tire
- Stability casters
- Extra Easy Exchange HD batteries and an optional external charger are available to support a virtually infinite duty cycle.

# Specifications

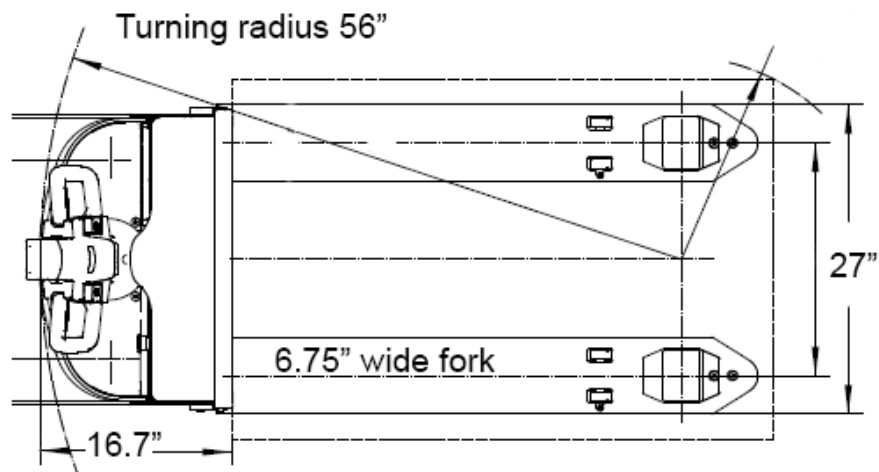
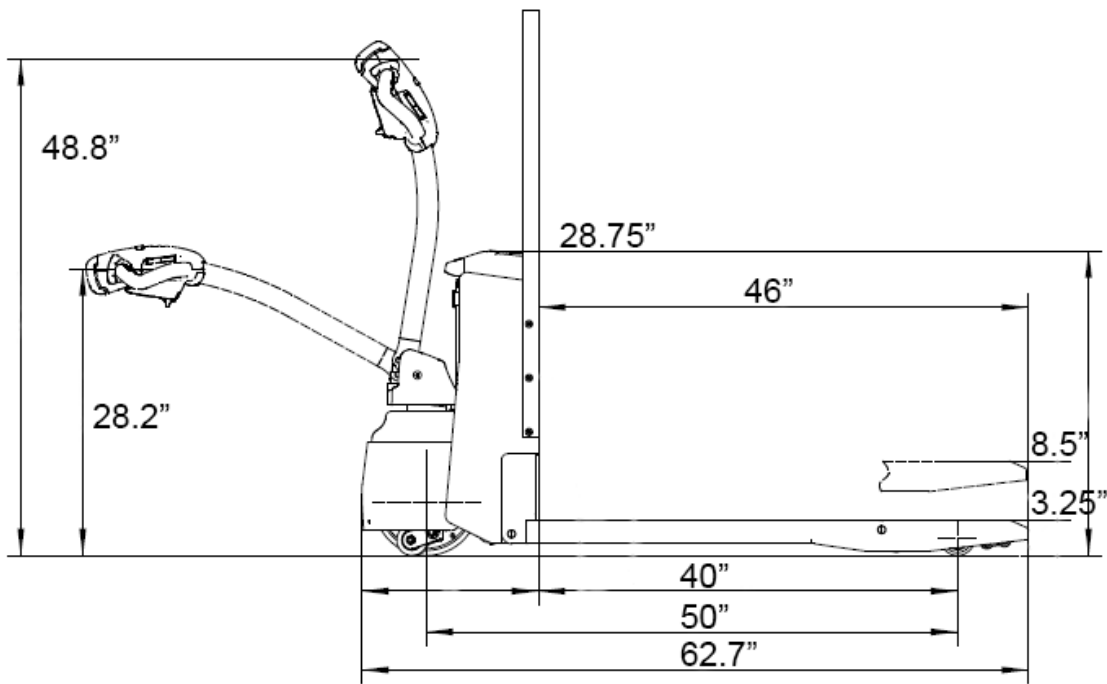

**BLUE GIANT**  
BLUE GIANT EQUIPMENT CORPORATION

Corporate 410 Admiral Blvd  
Mississauga, ON, Canada L5T 2N6  
t 905.457.3900 f 905.457.2313

USA 6350 Burnt Poplar Road  
Greensboro, NC 27409  
[www.bluegiant.com](http://www.bluegiant.com)



CUSTOMERS FOR LIFE

Blue Giant offers a full line of dock levelers, dock safety equipment, seals and shelters, accessories, ergonomic and scissor lift equipment and industrial trucks. Concurrent with our continuing product improvement program, specifications are subject to change without notice. Please contact Blue Giant for latest information. Some features illustrated may be optional in certain market areas.