

Electric Powered Pallet Truck **BLUE GIANT**[®]

EPJ-45

Low cost electric pallet truck, ideal for crowded loading docks, work cells and congested aisles.

CAPACITY

- 4500 lb (2041 kg)

BATTERY

- 24-volt 224 AH AGM maintenance-free battery pack with built-in 110V AC charger
- Minimum battery weight: 175 lb (79.4 kg)
- AH capacity (min/max): 180/255
- Compartment dimensions (open): 26.4" x 9.1" (671 mm x 231 mm)
- Connector: SB-175 Gray—A-11

SPEED

- **EMPTY:** 0 - 3.66 mph (5.9 kph)
- **LOADED:** 0 - 3.5 mph (5.6 kph)

TIRES / WHEELS

- **DRIVE:** 9" x 3" (229 mm x 76 mm) polyurethane
- **LOAD:** 3.3" x 4.5" (84 mm x 114 mm) polyurethane
- Press-on polyurethane drive tire

HYDRAULICS

- Lift cylinder with hard chrome plated rods
- Pump unit including motor, gear pump, and solenoid are actuated using pressure compensated lowering valve

ELECTRICAL

- 24-volt ZAPI AC-0 travel control-inverter with matching drive motor provides high performance throughout the entire speed range
- Monarch drive motor
- Automatic rise and fused circuit protection
- Low battery lift interrupt
- Hour meter / battery discharge indicator combo

BRAKES

- Regenerative electromagnetic brake mounted on motor armature shaft, multiplying braking power through the transmission
- ZF GK10 transmission
- Brake is applied when control arm is in the vertical or horizontal position
- Neutral braking resists roll back on ramp

OPERATION / CONTROLS

- Ergonomic operator handle with travel, lift, and lower functions
- Angle grips allow easy operation with either hand
- Wrap-around guard
- Reversing switch
- Thumb control and horn



- Gas-assisted spring handle
- Creep speed function while steer handle is at 5° back-tilt from vertical

TRANSMISSION

- Vertically mounted drive motor direct mounted to gear housing
- Oil-bathed ZF GK10 hypoid bevel gear drivetrain
- State-of-the-art optimized gear technology provides minimal envelope circle, zero maintenance, and low noise level

BEARINGS

- **DRIVE WHEEL:** Tapered roller bearings sealed in oil bath
- **LOAD WHEELS:** Sealed ball bearings
- **FORK LINKAGE:** Self-lubricated heat-treated bushing

ACCESSIBILITY

- Removal of one piece power head cover exposes major components for inspection and maintenance
- Drive tire can be removed with one nut

STANDARD EQUIPMENT

- Steel wrap-around bumper

OPTIONAL EQUIPMENT

- Fork lengths: 36" or 60" (914 or 1524 mm)
- Fork widths: 18" or 21" (457 or 533 mm)
- 48" (1219 mm) tall load back rest
- Stability casters
- Cold conditioning
- 8.1" (206 mm) battery compartment

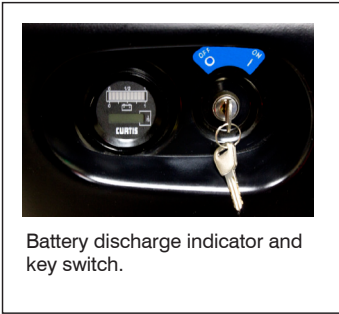

Battery discharge indicator and key switch.

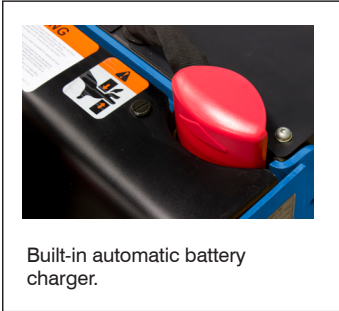

Built-in automatic battery charger.



Ergonomic operator's handle

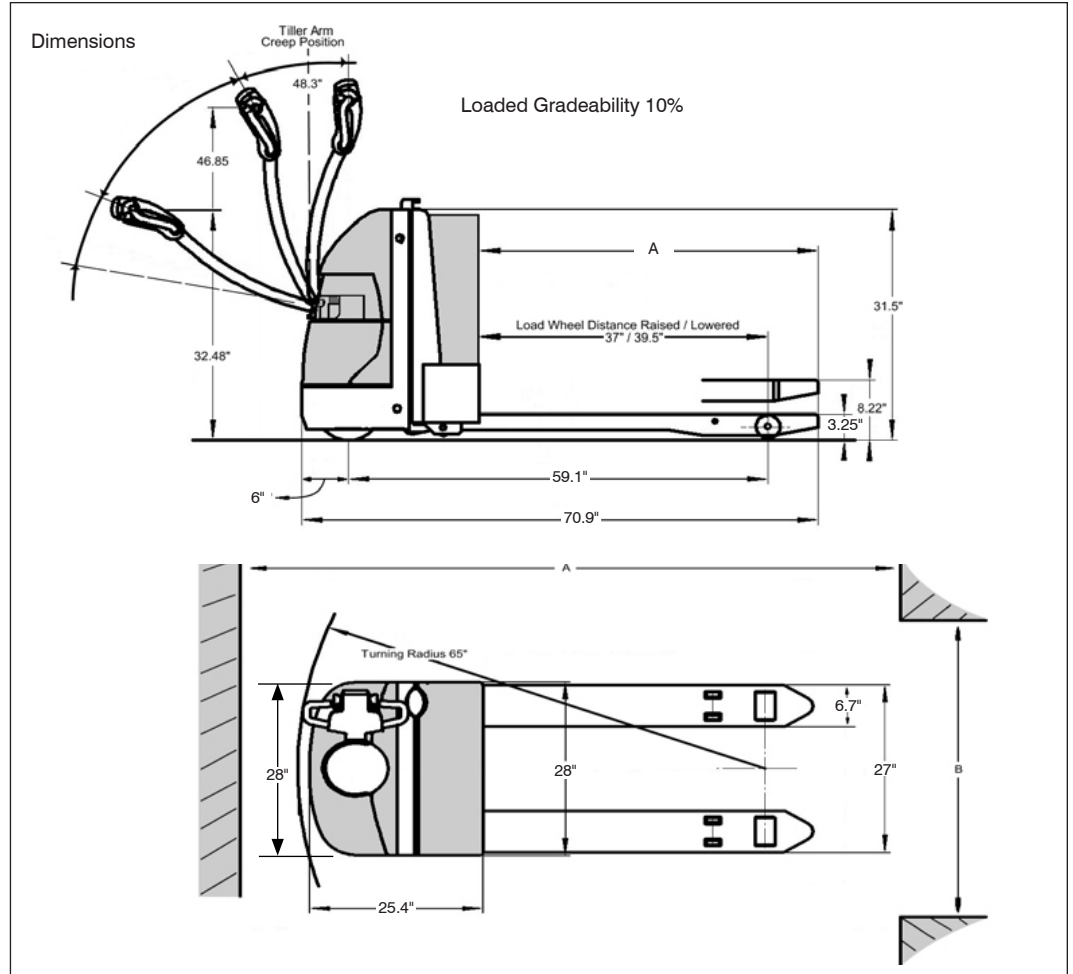

| Gradeability | |
|-------------------|--------------|
| Without Load | 10% |
| With Load | 6% |
| Travel - Variable | |
| Empty | 0 to 3.6 mph |
| Loaded | 0 to 3.5 mph |

| Model# | Forks | Actual Fork Width | Actual Fork Length | Turning Radius | Wheel-base | Overall Length | Inside Fork Width | Weight* | |
|---|------------------------------|-------------------|--------------------|------------------|--------------------|--------------------|-------------------|---------|-----|
| | | | | | | | | lb | kg |
| Fork Dimension: 27" (686mm) Wide | | A | B | C | D | E | F | | |
| EPJ-45 | 27" x 36" (686 x 914 mm) | 27" (686 mm) | 33.5" (851 mm) | 56" (1422 mm) | 50.1" (1273 mm) | 61.9" (1572 mm) | 13.4" (340 mm) | 875 | 397 |
| | 27" x 48" (686 x 1219 mm) | | 45.5" (1156 mm) | 68" (1727 mm) | 59.1" (1501 mm) | 70.9" (1800 mm) | | 885 | 401 |
| | 27" x 60" (686 x 1524 mm) | | 57.5" (1461 mm) | 80" (2032 mm) | 73.7" (1872 mm) | 85.5" (2171 mm) | | 910 | 413 |
| Fork Dimension: 21" (533mm) Wide | | | | | | | | | |
| EPJ-45 | 21" x 36" (533 x 914 mm) | 21" (533 mm) | 33.5" (851 mm) | 56" (1422 mm) | 50.1" (1273 mm) | 61.9" (1572 mm) | 7.6" (193 mm) | 875 | 397 |
| | 21" x 48" (533 x 1219 mm) | | 45.5" (1156 mm) | 68" (1727 mm) | 59.1" (1501 mm) | 70.9" (1800 mm) | | 880 | 399 |
| Fork Dimension: 18" (457mm) Wide | | | | | | | | | |
| EPJ-45 | 18" x 36" (457 x 914 mm) | 18" (457 mm) | 33.5" (851 mm) | 56" (1422 mm) | 50.1" (1273 mm) | 61.9" (1572 mm) | 4.6" (117 mm) | 875 | 397 |
| | 18" x 48" (457 x 1219 mm) | | 45.5" (1156 mm) | 68" (1727 mm) | 64.9" (1648 mm) | 70.9" (1800 mm) | | 880 | 399 |

Dimensions listed above are based on 9.1" battery compartment

* Estimated shipping weight with (2) battery



Corporate 85 Heart Lake Road South
Brampton, ON, Canada L6W 3K2
t 905.457.3900 f 905.457.2313

USA 6350 Burnt Poplar Road
Greensboro, NC 27409
www.BlueGiant.com



Blue Giant offers a full line of dock levelers, dock safety equipment, seals and shelters, accessories, ergonomic and scissor lift equipment and industrial trucks. Concurrent with our continuing product improvement program, specifications are subject to change without notice. Please contact Blue Giant for latest information. Some features illustrated may be optional in certain market areas.