

# Powered Drive Straddle Truck **BLUE GIANT®**

## BGN-40

Short turning radius makes it an excellent choice for narrow aisles, tool rooms or street level loading.

### CAPACITY

- 4000 lb (181 kg) at 24" (610 mm) load center

### BATTERY

- Minimum battery\* weight: 1090 lb (494 kg)
- Compartment dimensions (open): 31.6" x 13.1" (803 x 333 mm)
- Connector: Anderson 175 Gray—A-11
- 224 AH battery package (4 - 6 AGM volt maintenance-free batteries) complete with complete with automatic 25 AMP / 110 VAC plug-in internal charger

### SPEED

- **EMPTY:** 0 - 3.4 mph (5.5 kph)
- **LOADED:** 0 - 3.1 mph (5 kph)
  
- **LIFT - EMPTY:** up to 37 fpm
- **LIFT - LOADED:** up to 32 fpm with 4000 lb (1814 kg) load
  
- **LOWERING - EMPTY:** up to 29 fpm
- **LOWERING - LOADED:** up to 56 fpm with 4000 lb (1814 kg) load

### TIRES / WHEELS

- **DRIVE:** 9" x 3" (228 x 76 mm) polyurethane
- **DUAL LOAD:** (2) 4" x 2.9" (101 x 74 mm) polyurethane

### HYDRAULICS

- Lift cylinder has hard chrome-plated rods
- Pump unit including motor, solenoid, gear pump, and pressure compensated lowering valves

### ELECTRICAL

- 24-volt ZAPI AC-0 inverter with matching drive motor provides high performance throughout the entire speed range
- Separately fused power control circuits
- Quick disconnect EPD power cut off
- Hour meter / battery discharge indicator combo
- Power configurations and diagnostic features are displayed with a ZAPI handheld console
- Low battery interrupt
- Travel speed remains constant relative to throttle position, regardless of load

### BRAKES

- Regenerative electromagnetic brake mounted on motor armature shaft, multiplying braking power through the transmission
- Brake is applied when control arm is in the vertical or horizontal position
- Neutral braking resists rollback on ramps



### OPERATION / CONTROLS

- Ergonomic operator handle with travel, lift, and lower functions
- Angle grips allow easy operation with either hand
- Wrap-around guard
- Reversing switch
- Thumb control
- Key switch and horn
- Top mounted tiller arm offers excellent operator comfort and minimum steering effort
- Gas-assisted spring handle
- Creep speed handle control

### TRANSMISSION

- Vertically mounted drive motor direct mounted to gear housing
- Oil-bathed ZF GK10 hypoid bevel gear drivetrain
- State-of-the-art optimized gear technology provides minimal envelope circle, zero maintenance, and low noise level

### FRAME AND MAST

- Bolt-on high-visibility mast, I-beam construction and lift cylinders positioned on outer I-beam for best view through mast
- Dual lifting chains
- Fixed straddle leg inside dimension (ID) of either 42" or 50" (1067 mm or 1270 mm)
- 4" (102 mm) wide straddle legs = ID + 8" (203 mm)
- Class II ITA fork carriage with 36" (914 mm) tall load back rest
- Forks are adjustable from 8" ID to 31" OD (203 mm to 787 mm)

### BEARINGS

- **DRIVE WHEEL:** tapered roller bearings sealed in oil bath
- **LOAD WHEELS:** sealed ball bearings

\* Battery and charger sold separately.

**ACCESSIBILITY**

- Removal of two piece power head cover exposes major components for inspection and maintenance

**OPTIONAL EQUIPMENT**

- 48" (1219 mm) tall load backrest
- Cold conditioning
- Side-shifting fork carriage
- Battery 510 AH 11.9 kWh

**Right Angle Stacking Aisle Dimensions**

Load Length	Load Width		
	36"	40"	48"
36"	79.5"	79.5"	79.5"
40"	80.5"	80.5"	80.5"
48"	80.5"	80.5"	80.5"

For ease of use add 8" to aisle dimension listed.  
If sideshift option is used add 2".

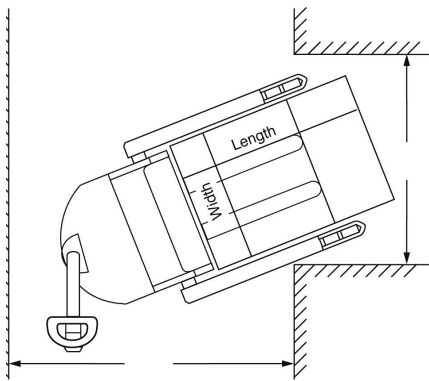

**Note:** Aisle dimensions listed above assume the minimum bay width to be straddle OD plus 5" (2.5" on each either side of straddle leg). Straddle OD is the load width plus 10". Truck performance may vary due to application requirements and changes in model design.

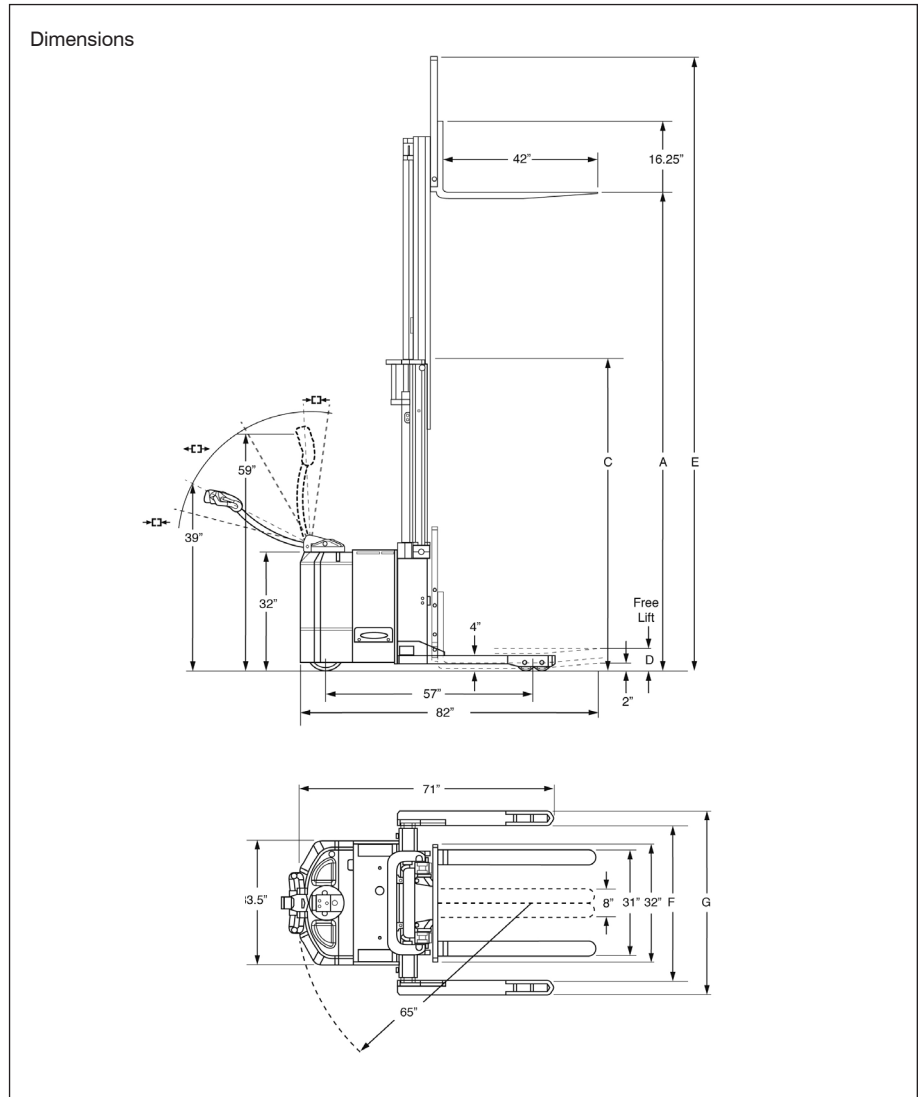

Model#	Mast	Lift Height	Col Height	Free Lift	Ext Height w/ LBR	<sup>2</sup> Fixed Straddle Leg (4" Increments)		<sup>3</sup> Weight (Chassis Only)
		A	C	D	E	ID	OD	
		F		G				
<b>4000 lb Capacity @ 24" Load Center ITA Class II Fork Carriage</b>								
BGN-40-104	Telescopic	104"	72"	6"	142"	42 or 50"	50" or 58"	2042 lb
BGN-40-126		126"	83"		165"			2172 lb
BGN-40-157	Trimast	157"	72"	50"	193"			2444 lb
*BGN-40-177		177"	80"	58"	213"			2539 lb

\* Derates 1000 lb above 162"  
<sup>2</sup> Minimum inside dimension (ID) 38". Outside dimension = inside dimension + 8"  
<sup>3</sup> Estimated shipping weight without battery



Corporate 410 Admiral Blvd  
 Mississauga, ON, Canada L5T 2N6  
 t 905.457.3900 f 905.457.2313

USA 6350 Burnt Poplar Road  
 Greensboro, NC 27409  
[www.bluegiant.com](http://www.bluegiant.com)



Blue Giant offers a full line of dock levelers, dock safety equipment, seals and shelters, accessories, ergonomic and scissor lift equipment and industrial trucks. Concurrent with our continuing product improvement program, specifications are subject to change without notice. Please contact Blue Giant for latest information. Some features illustrated may be optional in certain market areas.