



BACKHOE LOADERS | 3CX COMPACT

Gross power: 74 hp (55 kW) Maximum dig depth: 14'2" (4.33 m) Weight: 13,514 lb (6,130 kg)



MORE COMPACT

THE 3CX COMPACT IS DESIGNED FOR BIG PERFORMANCE IN SMALL SPACES, MAKING IT PERFECT FOR CONFINED AND URBAN JOB SITES.



1 The 3CX COMPACT is 35 percent smaller than a standard backhoe loader.

2 At 6 feet 6 inches (1.99 m) wide and 9 feet (2.74 m) high, the 3CX COMPACT is 20 inches (0.5 m) narrower and 25 percent lower than a standard 3CX SUPER.

3 The narrow width allows entry to smaller work sites with narrow access.

4 The low working height allows the 3CX COMPACT to work within previously inaccessible work sites, such as low-level buildings and basements.

The 3CX COMPACT has a turning circle of just 19 feet (5.8 m), and the 6-foot 6-inch (1.99 m) width means it can work within a single road lane, allowing other lanes to remain open.

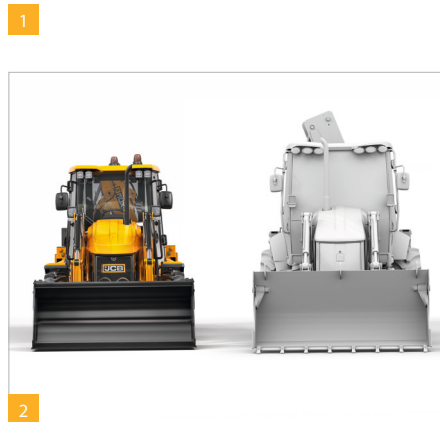

35% smaller than
a standard
backhoe.



MORE MOBILE & MANEUVERABLE

THE 3CX COMPACT IS THE ULTIMATE IN MANEUVERABILITY; A TIGHT TURNING CIRCLE AND SWITCHABLE STEERING MODES PERMIT WORK WITHIN A SINGLE ROAD LANE FOR MINIMAL DISRUPTION AND MAXIMUM PRODUCTIVITY.

- 1 Auto switchable 2WS/4WS allows the operator to change from roading to site work with ease.
- 2 A three-speed hydrostatic transmission enables the 3CX COMPACT to travel at speeds up to 25 mph (40 km/h). Consequently, the 3CX COMPACT is a highly independent machine with a large working radius, reducing the need for additional transport equipment.
- 3 The 3CX COMPACT is powered by a high torque 74 hp (55 kW) JCB by Kohler engine that requires no aftertreatment, to keep servicing costs and downtime to a minimum.

- 4 Vari Speed transmission is standard on the 3CX COMPACT PLUS and allows the operator to preselect a preferred forward speed for attachments such as sweeper brushes and collectors.

Vari Speed PRO transmission is standard on the 3CX COMPACT PRO and allows the operator to preselect and maintain a preferred forward speed while driving on varying terrain, which is beneficial for using attachments such as trenchers and cold planers.

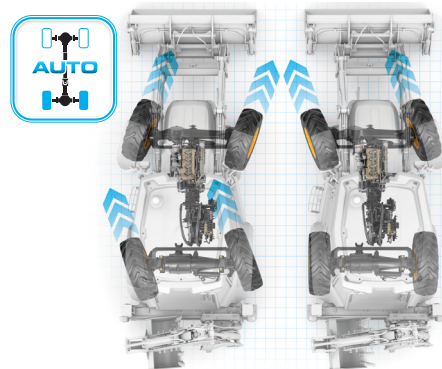

1 Four-wheel steer Two-wheel steer



2



3

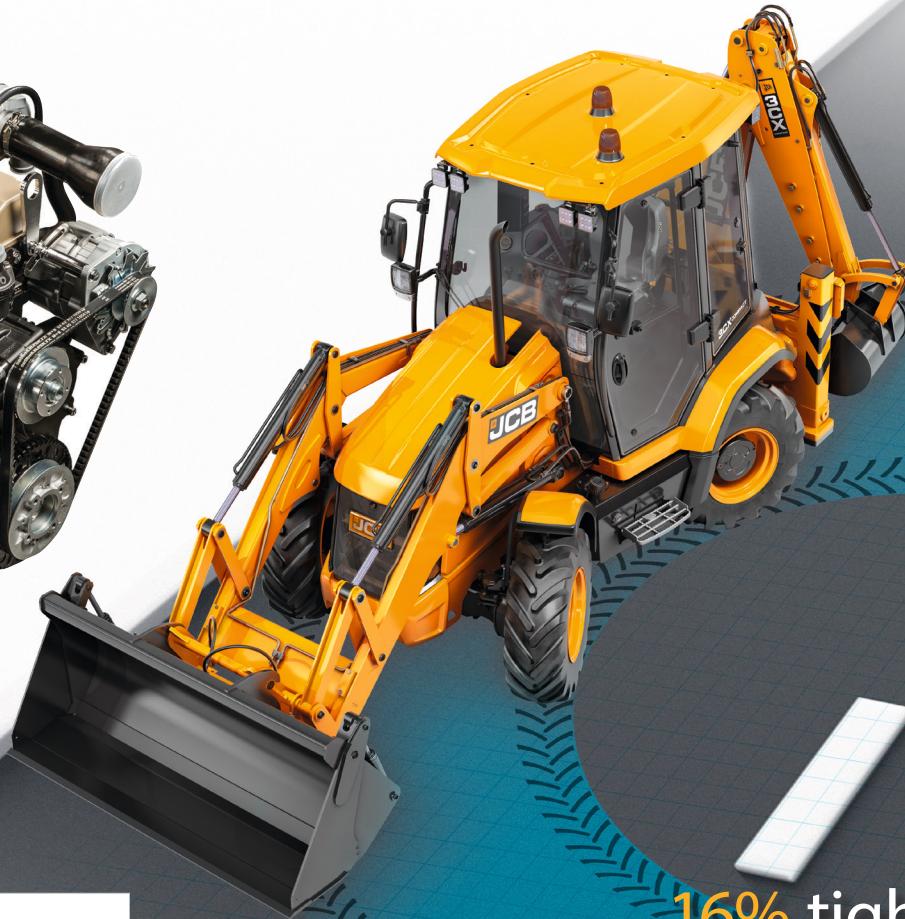

The impressively small 19-foot (5.8 m) turning circle (with applied brakes) allows the 3CX COMPACT to turn 180 degrees within the width of a two-way street.

16% tighter turning circle than a full-size backhoe.



4

MORE COMFORT

A SPACIOUS CAB WITH EXCAVATOR CONTROLS MAKES THE 3CX COMPACT EASY TO USE AND CONTROL AND THE OPTIMIZED SEAT POSITION MAKES IT COMFORTABLE TO OPERATE FOR EXTENDED PERIODS.

1 Excavator-style controls fitted as standard make the 3CX COMPACT easy to use and simple to control.

2 The JCB SmoothRide System increases operator comfort on-and-off-road, and improves load retention.

3 The available Powerslide option enables effortless repositioning of the side-shift excavator end, to reduce effort for the operator, save time in repositioning the machine and minimize ground damage.

4 The 3CX COMPACT features ample internal and external storage space for a better organized cab and improved comfort.

5 A 12-volt auxiliary circuit powers personal mobile devices and other useful accessories.

6 The 3CX COMPACT PLUS features a twin control lever with Mk2 loader coupler or a single control lever with skid steer loader coupler.

7 The 3CX COMPACT PRO features a 7-way multifunction lever with skid steer loader coupler.



Spacious 3CX COMPACT cab.



MORE VERSATILE

THE 3CX COMPACT EASILY HANDLES A WIDE RANGE OF BACKHOE LOADER ATTACHMENTS OR HIGH-POWERED SKID STEER LOADER ATTACHMENTS.



The 3CX COMPACT efficiently does the work of a compact excavator, front-end loader and even a skid steer loader when equipped with the available skid steer coupler.



The **versatile**, one-machine solution.



1 The 3CX COMPACT is designed for a vast range of tool carrier or skid steer loader attachments. Bi-directional excavator pipework and an available hand-held tool circuit provide even greater versatility.

2 With 31.7 gpm (120 l/min) auxiliary flow, the 3CX COMPACT can accommodate high-power attachments such as patch planers.

3 The available hand-held tool auxiliary circuit provides power for a range of versatile equipment, including water pumps, hand breakers, power tools, and disc breakers.

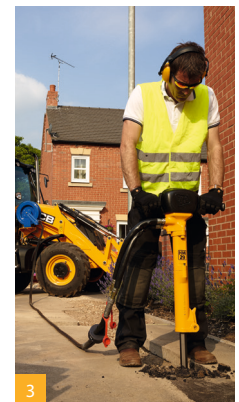

MORE SAFE & SECURE

THE 3CX COMPACT COMES STANDARD WITH MANY SAFETY FEATURES TO KEEP THE OPERATOR SAFE AND PROTECT THE OWNER'S INVESTMENT.

1 With a simple, programmable numerical key-code, the available immobilizer prevents unauthorized use.



2 An optional fish-eye mirror provides full visibility to all rear attachments and blind spots.

The door sensor isolates loader auxiliary constant flow to prevent unsafe operation of attachments.

3 Daily checks are performed at ground level, making greasing and servicing safer.



The large fuel tank is also accessible at ground level, for safer refuelling.

4 360-degree visibility from the cab allows the operator to maintain greater situational awareness, to make the work site safer for everyone.





5 LED beacon and LED work lights provide clear vision during all hours of the day.

6 The step light provides greater visibility for accessing the cab in low-light conditions.

7 Two anti-slip steps, with open grill design to prevent dirt build-up, provides safe entry and exit.

8 JCB's LiveLink telematics system allows the machine status to be monitored remotely from anywhere in the world using a desktop computer or smart mobile device.

9 The operator can easily maintain three points of contact when entering or exiting the machine.



MORE OPTIONS



LED worklights and beacons

Improve visibility at all hours of the day, especially in low-light conditions.



Tool boxes

Lockable external and internal tool boxes for safe and secure storage of tools.



Periscope mirror

Enhance visibility to all front-end attachments.



Front and rear camera

Provide the operator with additional visibility while reversing the machine, essential when working on busy sites or where pedestrians are in close proximity.

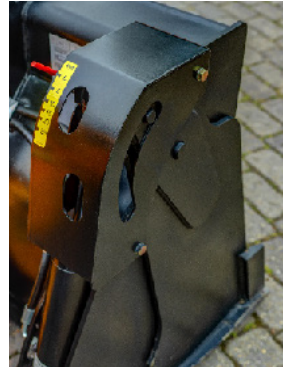

Clam/Ram guards

Improve reliability by protecting rams from debris.



Immobilizer

Program a numerical key-code to prevent unauthorized use.



Lifting kits

Enable the machine to perform lifting operations. Hose-burst check valves and an audible warning alarm maximize site safety.



Fish eye

Mirror provides full visibility to all rear attachments and blind spots.



Hand held tool circuit
Deliver hydraulic power to a range of versatile, hand-held equipment, including water pumps, hand breakers, power tools and disc breakers.



ISO/SAE
Choose optional SAE+/ISO+ control panel switch.



Step Lights
Improve visibility when accessing or exiting the cab in low-light conditions.



Powerslide
Enable effortless repositioning of the side-shift boom, to reduce effort for the operator, save time in repositioning the machine and minimize ground damage.

Rear quick hitch
Switch easily between attachments with a rear mechanical quick hitch for maximum versatility on any job.

MORE TIRE OPTIONS

SELECT FROM A RANGE OF TIRES TO SUIT A WIDE VARIETY OF INDUSTRIES, APPLICATIONS AND GROUND CONDITIONS.



Sitemaster

The JCB Sitemaster features cross-ply construction for good performance, value and durability.

12.5-18-10



Michelin Power CL

The cross-ply Power CL tire provides strength and stability with a high resistance to impacts and punctures. The sidewall integrity gives excellent vertical and lateral stability.

340/80-18



Michelin XMCL

The radial construction of the XMCL gives excellent traction in dry or wet conditions. This tire provides great wear characteristics and exceptional comfort on the road.

340/80 R18



Michelin Bibload

The Bibload tire is a true hard surface tire that resists wear and tear and improves ride quality. The strong sidewall construction reduces the risk of punctures and offers exceptional lateral stability for a radial tire.

340/80 R18



Michelin XP27

The XP27 reduces ground damage and is well suited for working at lower pressures, making it an ideal choice for working on turf. The XP27 also provides a low rolling resistance for better fuel efficiency.

340/65 R18

3CX COMPACT PLUS

THE 3CX COMPACT PLUS IS IDEAL FOR GENERAL CONSTRUCTION, LANDSCAPING, UTILITY AND MUNICIPALITY APPLICATIONS. WITH CONSTANT FLOW AND VARI SPEED TRANSMISSION, IT IS WELL SUITED FOR USE OF LOW-FLOW SWEEPER/COLLECTORS OR TRENCHERS. AN OPTIONAL SKID STEER QUICK COUPLER INCREASES VERSATILITY AND USE OF A WIDER RANGE OF LOW-FLOW ATTACHMENTS.



Power	74 hp (55 kW)	
Travel speed	25 mph (40 km/h)	
Transmission	Hydrostatic + Vari Speed	
Loader lever	Single lever with skid steer quick hitch	
Front auxiliary flow	18.5 gpm (70 l/min) + constant flow	
Excavator	12' fixed	12' extending
GP	4	
Mk2 QH	Optional	
5/8 pipework	4	
Constant flow	4	
Auto 2WS/4WS	4	
Powerslide	Optional	



3CX COMPACT PRO

THE 3CX COMPACT PRO IS IDEAL FOR ROAD WORK, SPECIALIZED CONSTRUCTION CONTRACTORS, SNOW CLEARING AND MUCH MORE. IT FEATURES 31.7 GPM (120 L/MIN) AUXILIARY FLOW TO THE LOADER, A SKID STEER QUICK COUPLER, VARI SPEED PRO TRANSMISSION AND A 7-WAY MULTI-FUNCTION LEVER.



Power	74 hp (55 kW)
Travel speed	25 mph (40 km/h)
Transmission	Hydrostatic + Vari Speed PRO
Loader lever	7-way multifunction
Front auxiliary flow	31.7 gpm (120 l/min) + constant flow
Excavator	12' extending
GP	4
SSL QH	4
5/8 pipework	4
Constant flow	4
7-way multi loader lever	4
Vari speed Pro	4
Auto 2WS/4WS	4
Powerslide	4



LIVELINK, WORK SMARTER

LIVELINK IS JCB'S INNOVATIVE TELEMATICS SYSTEM TO MANAGE MACHINES REMOTELY FROM ANYWHERE IN THE WORLD FROM A DESKTOP COMPUTER OR MOBILE SMART DEVICE.

Productivity and cost benefits – By providing information such as idle time monitoring and machine fuel consumption, JCB LiveLink helps reduce fuel usage, save money and improve productivity. Machine location information can help improve efficiency and possibly reduce insurance costs.



Maintenance benefits – Accurate hours monitoring and service alerts improve maintenance planning, while real-time location data helps you manage your fleet. Critical machine alerts and maintenance history records are also available.

Security benefits – Alerts for ge-fencing inform you when a machine moves out of predetermined operating zones, and alerts for real-time curfew let you know if machines are being used when they're not supposed to be. Real time location information helps store machines safely.

VALUE ADDED

WHATEVER YOU NEED AND WHEREVER YOU ARE, JCB'S DEPENDABLE NORTH AMERICAN DEALER NETWORK IS HERE TO MAKE SURE YOUR MACHINERY PERFORMS TO ITS FULL POTENTIAL.



1 JCB Technical Support Service provides instant access to factory expertise, day or night. The global network of JCB Parts Centers is a model of efficiency. With 16 regional bases, JCB delivers around 95 percent of all parts anywhere in the world within 24 hours. Genuine JCB parts are designed to work in perfect harmony with your machine for optimum performance and productivity.



2 JCB Yellow Shield offers comprehensive extended warranties, as well as service-only or repair and maintenance contracts. JCB maintenance teams offer competitive labor rates and no-obligation quotes.



Note: JCB LiveLink and JCB Yellow Shield may not be available in your region, so please check with your local dealer.

STATIC DIMENSIONS

Max. engine power: 74 hp (55 kW) max. dig depth: 14'2" (4.33 m)

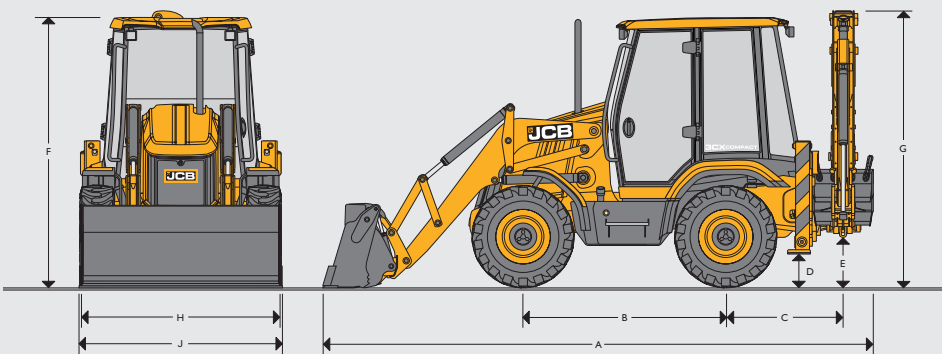

		3CX COMPACT	
A	Total travel length	ft-in (m)	18-1 (5.52)
B	Axle centerline distance	ft-in (m)	6-6 (1.99)
C	Slew center to rear axle center distance	ft-in (m)	3-10 (1.16)
D	Stabilizer feet clearance	ft-in (m)	1-1 (0.33)
E	Kingpost clearance	ft-in (m)	1-8 (0.52)
F	Cab roof height	ft-in (m)	8-8 (2.65)
G	Total travel clearance (10 ft)	ft-in (m)	9-0 (2.74)
	Total travel clearance (12 ft)	ft-in (m)	10-1 (3.08)
H	Rear frame width	ft-in (m)	6-2 (1.89)
J	Shovel width	ft-in (m)	6-2 (2.01)

Machine features heavy-duty one piece mainframe, hydrostatic driveline and fully enclosed engine compartment. All fluid and component compartments are lockable using the ignition key

GROUND LINE ANGLES

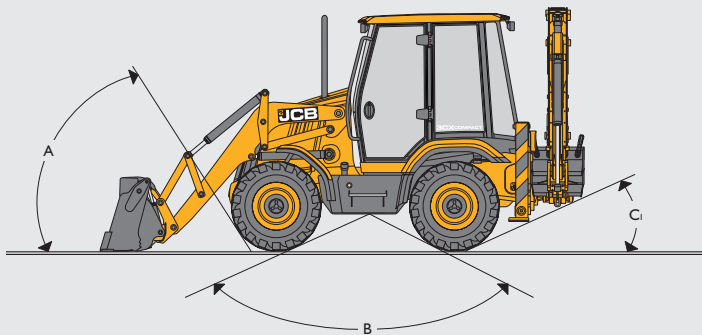

A	Approach angle	degrees	45
B	Interference angle/ramp to ground plane	degrees	124.5
C	Departure angle	degrees	19

ENGINE

Common rail diesel. Belt driven water pump. Cold start aid – territory dependent. Single side servicing.

Engine emissions		Stage IIIB/T4F
Manufacturer		JCB Diesel by Kohler
Gross power	hp (kW)	74 (55) @ 2,200 RPM
Peak torque	lb-ft (Nm)	221.3 (300)
Aspiration		Turbo charged
Displacement	liters	2.4
No. of cylinders		4
Bore	in (mm)	3.4 (88)
Stroke	in (mm)	4.0 (102)
Rated engine	RPM	2,350

TRANSMISSION

Bosch Rexroth transmission with anti-stall and high speed roading switch.

Type		Hydrostatic
Model		Rexroth A6VM – 3 speed
1st (low range)	mph (km/h)	6 (3.7)
2nd (high range)	mph (km/h)	10 (6.2)
3rd (high speed)	mph (km/h)	40 (24.9)

SERVICE CAPACITIES

Cooling system	gal (l)	4.23 (16)
Fuel tank	gal (l)	21.13 (80)
Engine oil sump	gal (l)	2.96 (11.2)
Hydraulic system (including transmission)	gal (l)	27.47 (104)
Rear axle	gal (l)	2.38 (9)

AXLES

	Front	Rear
Type	JCB Max-trac steer drive torque proportioning standard, LSD - limited slip differential optional	
Axle ratings	lb (kg)	
Static load rating	16,499 (7,484)	
Dynamic load rating	8,300 (3,765)	
Oscillation angle	9.5°	–
Steering ram	Double acting	Double acting

STEERING

Steering axles	Front and rear
Steering turns – lock to lock	4
Turning circle:	ft-in (m)
Inner wheels braked	19-0 (5.8)
Inner wheels not braked	22-0 (6.7)

OPERATING WEIGHTS

12 ft fixed	lb (kg)	13,018 (5,905)
12 ft extradig	lb (kg)	13,514 (6,130)

Operating weight includes machine with Cab A/C, 6-in-1 shovel, 24" (600mm) excavator bucket, extended dipper, full fuel tank and operator. Actual weight will vary depending on machine options.

NOISE AND VIBRATION LEVELS

Internal	dB(A)	71
External	dB(A)	101

LOADER DIMENSIONS

		G.P. shovel ft-in (m)	6-in-1 shovel ft-in (m)
	Overall width with bucket	6-7 (2.01)	6-7 (2.01)
M	Dump height	7-1 (2.147)	7-9 (2.35)
N	Load over height	9-9 (2.96)	9-11 (3.02)
O	Loader hinge pin height	10-6 (3.20)	10-6 (3.20)
P	Pin forward reach	1-5 (0.43)	1-5 (0.43)
Q	Reach at ground (toe plate horizontal)	5-0 (1.52)	5-0 (1.52)
R	Max. reach at full height	3-10 (1.16)	3-10 (1.16)
S	Reach at full height fully dumped	2-1 (0.64)	2-7 (0.79)
T	Dig depth	0-6 (0.15)*	0-6 (0.15)*
U	Roll back at ground	45°	45°
V	Dump angle	45°	45°
	Jaw opening width	-	0.7

*with quick hitch.

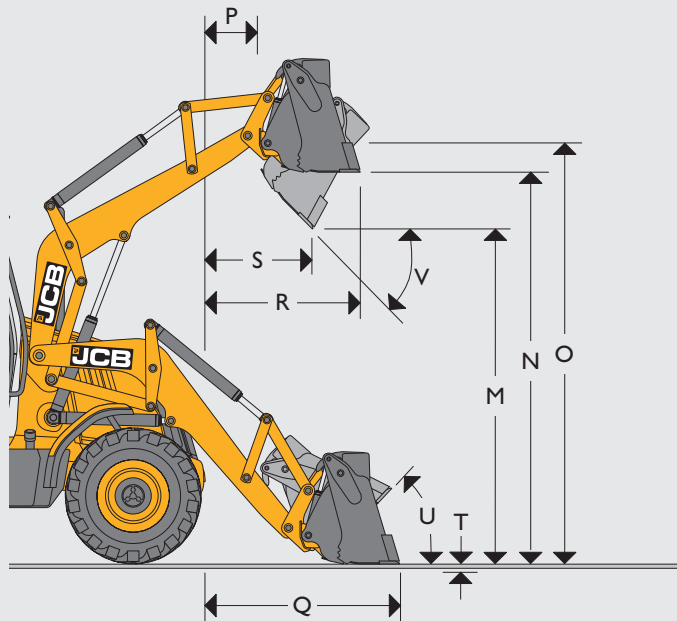

EXCAVATOR DIMENSIONS

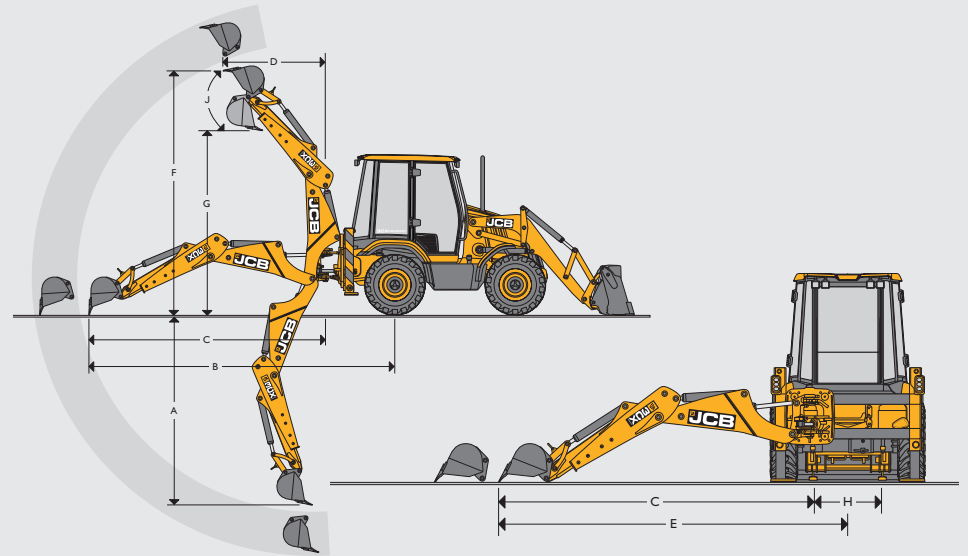

			12 ft fixed dipper		12 ft extending dipper	
			ft-in (m)	ft-in (m)	ft-in (m)	ft-in (m)
A	SAE max. dig depth	ft-in (m)	Ext	-	14-4 (4.36)	
		Ret	11-1 (3.38)	11-1 (3.38)		
	SAE 2ft flat bottom	ft-in (m)	Ext	-	14-0 (4.27)	
		Ret	11-0 (3.36)	11-0 (3.36)		
B	Reach - ground level to rear wheel center	ft-in (m)	Ext	-	6.43	
		Ret	19-1 (5.82)	19-1 (5.81)		
C	Reach - ground level to slew center	ft-in (m)	Ext	-	17-1 (5.21)	
		Ret	15-1 (4.60)	15-1 (4.60)		
D	Reach - at full height to slew center	ft-in (m)	Ext	-	10-5 (3.17)	
		Ret	8-11 (2.71)	8-11 (2.71)		
E	Side reach - to center line of machine	ft-in (m)	Ext	-	18-1 (5.52)	
		Ret	16-1 (4.91)	16-11 (5.15)		
F	SAE operating height	ft-in (m)	Ext	-	16-4 (4.97)	
		Ret	15-0 (4.57)	15-0 (4.57)		
G	Max. loadover height	ft-in (m)	Ext	-	12-4 (3.75)	
		Ret	10-0 (3.05)	10-0 (3.05)		
	SAE loadover height	ft-in (m)	Ext	-	12-1 (3.69)	
		Ret	10-11 (3.32)	10-10 (3.29)		
H	Total kingpost travel	ft-in (m)		3-3 (1.00)	3-3 (1.00)	
J	Bucket rotation			187°	187°	



ONE COMPANY, MORE THAN 300 MACHINES.

BACKHOE LOADER 3CX COMPACT

Gross power: 74 hp (55 kW) Maximum dig depth: 14'2" (4.33 m) Weight: 13,514 lb (6,130 kg)

JCB North America

2000 Bamford Blvd., Pooler, Georgia, 31322 Tel: (912) 447-2000

Download the very latest information on this product range at www.jcb.com

JCB inc. All rights reserved. No part of this publication may be reproduced, stored in a retrieval system, or transmitted in any form or by any other means, electronic, mechanical, photocopying or otherwise, without prior permission from JCB inc. All references in this publication to operating weights, sizes, capacities and other performance measurements are provided for guidance only and may vary dependent upon the exact specification of machine. They should not therefore be relied upon in relation to suitability for a particular application. Guidance and advice should always be sought from your JCB Dealer. JCB reserves the right to change specifications without notice. Illustrations and specifications shown may include optional equipment and accessories. The JCB logo is a registered trademark of J.C. Bamford Excavators Ltd.

Your nearest JCB Dealer



9999/5922 12/19 en-US Issue 6 DWUSA 5409.02

[f /JCBNA](https://www.facebook.com/JCBNA)
[t /JCBNA](https://twitter.com/JCBNA)
[y /JCBNORTHAMERICA](https://www.youtube.com/channel/UCJCBNA)

