



Polaris Introduces  
**THE ALL-NEW TAYLOR-DUNN TT-416**



The most ergonomic tow tractor in its class.





65 Years of  
Vehicle Innovation



70 Years of  
Industrial Reliability

## ALL-NEW **TT-416** STAND UP TOW TRACTOR

Polaris introduces the Taylor-Dunn TT-416, the industry's only tow tractor with full front and rear suspension, and largest operator compartment in its class. The **TT-416** delivers the reliability and performance you'd expect from Taylor-Dunn, all the ingress and egress benefits of a stand-up, but in the most ergonomic package ever offered in its class.

**5' x 5'**  
Aisle Turning



**36-Volt**  
AC Motor



**16,000 LB**  
Towing



Largest Operator  
Compartment

Only Tug with Front &  
Rear Suspension

# ENGINEERED IN PARTNERSHIP WITH MAJOR MANUFACTURERS TO OPTIMIZE...



## SAFETY



Safety Headlights and  
Large Front Push Bumper



## LABOR EFFICIENCY



Two Sided Emergency  
Shut Off Buttons



Control Panel with Battery Meter,  
Horn, Hi-Low Speed Switch



## PRODUCTIVITY



350 LB Capacity  
Operator Compartment



Easy Access  
Battery Compartment



Front Dual Coil Suspension and Rear  
Coil Suspension with Shock Absorbers

**PERFORMANCE**

<b>DRAWBAR PULL</b>	320 lb / 1.4kN
<b>MAX SPEED (UNLOADED)</b>	7 mph / 11.3 km/h
<b>TURNING RADIUS</b>	60 in / 152.4 cm
<b>TOW CAPACITY</b>	14,000 lb / 6,350 kg at 7mph (Equipped) 16,000 lb / 7,257 kg at 6mph (Factory Option)

**DIMENSIONS**

<b>OVERALL LENGTH</b>	102 in / 259 cm
<b>OVERALL WIDTH</b>	40.5 in / 103 cm
<b>OVERALL HEIGHT</b>	87 in / 221 cm (with Lightbar)
<b>WHEEL BASE</b>	41 in / 104 cm
<b>GROUND CLEARANCE</b>	2.5 in / 6.4 cm

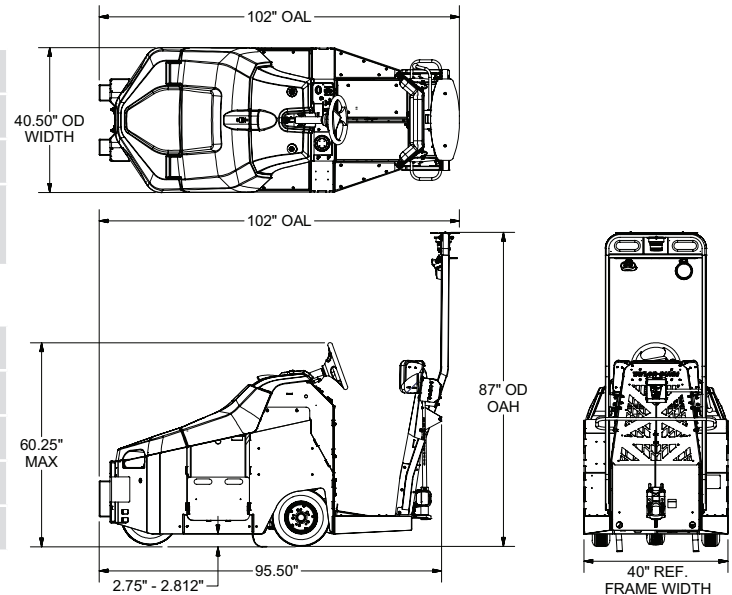
**POWER SUPPLY / DRIVE TRAIN**

<b>SYSTEM VOLTAGE</b>	36 Volt
<b>MOTOR</b>	10 Hp AC
<b>DRIVE AXLE</b>	GT automotive differential
<b>BATTERY</b>	Multiple options
<b>BATTERY COMPARTMENT</b>	37.75" L x 15.25" W x 23.625" H / 95cm L x 38cm W x 60cm H
<b>CHARGER</b>	AC Controller, 36V, DC/DC Converter, on with key switch, with automatic e-brake
<b>CONTROLLER</b>	AC speed controller, 480 amp

**CHASSIS**

<b>FRAME</b>	Fully welded, unitized, 3/8 inch steel
<b>STEERING</b>	Power steering with adjustable wheel height
<b>SUSPENSION</b>	Front dual coil suspension and rear coil suspension with shock absorbers
<b>BRAKES</b>	Rear wheel hydraulic disc brakes with regenerative braking and automatic parking brake
<b>TIRES</b>	4.00 x 8, soft solid, non-marking, traction tread

**GENERAL**

<b>MAXIMUM OCCUPANCY</b>	1 / 350 lb (159 kg)
<b>UNIT WEIGHT</b>	2,200 lb / 998 kg (LESS BATTERY)
<b>INSTRUMENTATION</b>	Smart View Display: (battery status indicator, hour meter, fault code display), key switch, light switch, reverse beeper and light switch, emergency power stop switch, DC / DC converter, dual USB port, electric horn
<b>OPTIONAL ACCESSORIES</b>	Dual LED headlights, running lights, brake lights, pedestrian warning light, light bar, front bumper, seatback wings, soft solid tires, and electronic power steering
<b>HITCH</b>	*Spring loaded E-type with hand release lever (*Optional)
<b>STORAGE COMPARTMENTS</b>	Cup holder, dual document slots and tablet compartment
<b>CONFORMANCE</b>	Type E OSHA 1910.178, ANSI B56.9
<b>WARRANTY</b>	2 YEAR / 2,000 HR

**FOR MORE INFORMATION VISIT**  
**FAIRCHILDEQUIPMENT.COM**

Final vehicle configurations to be determined. Specs are subject to change.