



C-425 AC – Class-leading towing for indoor and outdoor applications.

VOLTAGE	48 volt
SPEED	8 mph / 12.8 km/h
RANGE	30 mi / 48 km
TURNING RADIUS	74.5 in / 189 cm
TOWING CAPACITY	15,000 lb* / 6,800 kg*



SAFETY

- Emergency stop switch
- Automatic braking on gas pedal release
- Reverse beeper
- Operator presence switch
- Textured steel anti-slip floor and pedals



PERFORMANCE/ RELIABILITY

- Larger battery capacity
- AC efficient motor
- Regenerative braking
- Powerful GT drive
- All steel construction



COMFORT

- Front and rear suspension
- Premium semi-suspension seat
- Large operator area
- Cab options for climate protection

(844) 432-4724

www.fairchildequipment.com



POLARIS®
COMMERCIAL

PERFORMANCE

TOW CAPACITY	15,000 lb / 6,800 kg
DRAWBAR PULL	300 lb / 1.4 kN
MAX SPEED (UNLOADED)	8 mph / 12.8 km/h
TURNING RADIUS	74.5 in / 189 cm

DIMENSIONS

OVERALL LENGTH	79.3 in / 201 cm
OVERALL WIDTH	39 in / 99 cm
OVERALL HEIGHT (- cab)	54 in / 137 cm
OVERALL HEIGHT (+ cab)	82.5 in / 209.5 cm
WHEEL BASE	43 in / 109 cm
STEP HEIGHT	19 in / 48 cm

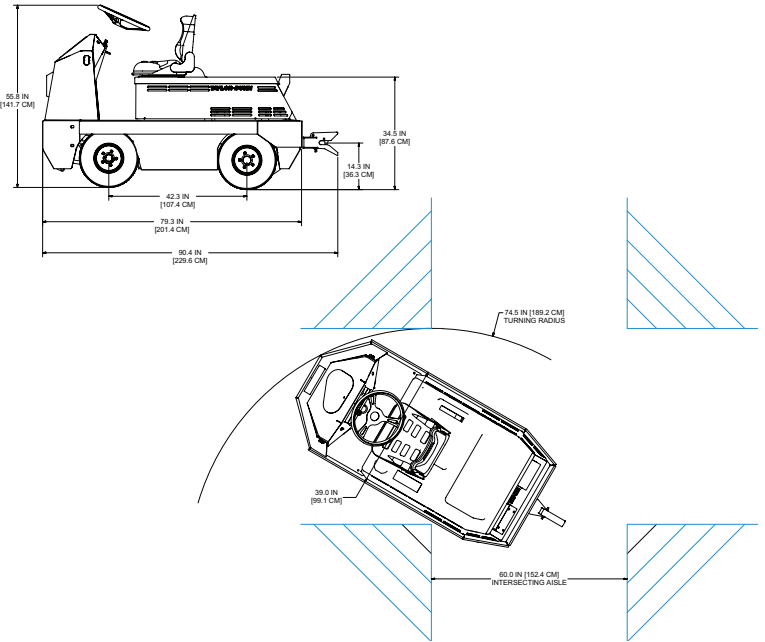

POWER SUPPLY / DRIVE TRAIN

MOTOR	16 HP AC
SYSTEM VOLTAGE	48 Volt
DRIVE AXLE	GT Automotive Differential
BATTERY	Less Battery, SB 350 Blue, 32L x 18.5W x 24H in (81L x 47W x 61H cm)
CHARGER	Less Charger
CONTROLLER	48 Volt AC

CHASSIS

FRAME	Fully Welded, Unitized, 10 Gauge Steel Body, 3/16" Steel Chassis, 1/2" Thick Steel Full Perimeter Steel Plate Protection
STEERING	Manual, Re-circulating Ball
SUSPENSION	Front and Rear Coil Springs, Rear Shock Absorbers
BRAKES	4-Wheel Hydraulic Disc, Automatic/Electric Parking Brake
TIRES	4.00 x 8, Load Range C, Pneumatic

GENERAL

MAXIMUM OCCUPANCY	1 / 250 lb (113 kg)
UNIT WEIGHT	1,635 lb / 742 kg
SEAT	Single, Adjustable, Black Vinyl, with Spring Suspension, Electric Interlock Switch
INSTRUMENTATION	Combination Display (Battery Status Indicator, Hour Meter, Fault Code Display, Speedometer), Forward/Reverse Selector, Key Switch, Electric Horn, Reverse Alarm, DC/DC Converter, Power Cut-off Switch
LIGHT ACCESSORIES	Headlight, Taillight, Brake Light, Reverse Light
HITCH	Less Hitch
CONFORMANCE	Type E OSHA 1910.178, ANSI B56.9

OPTIONS

- Wall Mount Charger
- Hitches
- Left-side Battery Extract
- Steel Cab
- Soft Solid Tires
- Various Hitches
- Custom Paint Color
- Undercoating

WARRANTY



PROCUREMENT



CONTRACT # 051717-PSI

* Based on Standard Configuration. Actual towing capacity is dependent on application, vehicle configuration, ballast weight, and operating environment. Note: Photos are shown with optional features. *Specifications, standard equipment, accessories and modifications are all subject to change without notice. Taylor-Dunn vehicles can be hazardous to operate and are not intended for on-road use. All riders should always wear safety protection as required for their jobsite and appropriate for operating conditions and intended usage, considering factors such as intended speed, unevenness of terrain, turns in path, vehicle traffic and other obstacles. Never engage in stunt driving, and avoid excessive speeds and sharp turns. Riding and alcohol/drugs don't mix. ©2019 Polaris Industries Inc.

(844) 432-4724

www.fairchildequipment.com

