



ARTICULATED TELESCOPIC HANDLER | TM320

Gross power: TM320: 125 hp (93 kW) Lift capacity: 6390 lb (2898 kg), Lift height: 17'1" (5,200 mm)



STRENGTH YOU CAN RELY ON.

THE TM320 IS DESIGNED AND BUILT WITHOUT COMPROMISE TO PROVIDE ALL THE STRENGTH AND POWER YOU NEED IN AN ARTICULATED MACHINE.



Proven reliability.

- 1 JCB machines are stress-tested over the equivalent of a lifetime of cycles, under the most arduous digging and dumping situations.
- 2 The centrally mounted lift, tilt and extension rams eliminate boom twisting, while centrally-mounted keyhole castings enhance the structural integrity.
- 3 JCB manufactures its own hydraulic cylinders, cabs, axles, transmissions and engines—all designed to work in perfect harmony for optimal reliability.
- 4 For long-term corrosion protection, cabs and bodywork panels are dipped in electrophoretic alloy prior to painting.



Designed to work hard.

5 A heavy-duty center joint absorbs vertical and horizontal load stress, for maximum durability and rigidity.

6 The boom is mounted into a heavy-duty loader tower and features an inverted-U profile and fully welded closing plates for exceptional strength.

7 The cast rear counterweight helps prevent impact damage. Recessed rear lights mounted above the counterweight are well protected.

8 Hydraulic hoses are routed within the main boom structure to guard against damage.

Wide core cooling pack with optional hydraulic reverse fan to eliminate debris build-up; the fan can be set to manual or automatic.



THE POWER TO PERFORM.

THE TM320 IS EQUIPPED WITH THE SUPERB JCB ECOMAX ENGINE AND OFFERS 17'1" LIFT HEIGHT, 9'8" FORWARD REACH AND CLASS LEADING LIFT CAPACITY AND TEAROUT FORCE.

JCB EcoMAX engine.

1 The JCB TM320 features the JCB EcoMAX Tier 4 Final engine with variable geometry turbo. This 4.4 liter engine delivers a massive 405 ft lb torque at low engine speeds for optimum response and improved cycle times and tractive effort.



Traction and travel.

2 With 4WD as standard, and optional limited slip differential, the JCB TM320 provide exceptional traction and performance on soft, muddy ground.

3 For improved load retention, comfort and productivity, the TM320 are equipped with JCB's Smooth Ride System (SRS).

SRS can be auto-engaged while traveling at speeds exceeding 4 mph (6 kph), manually engaged via a rocker switch (with the boom in any position), or constantly activated.



A unique oscillating center-pivot point maintains even weight distribution over each of the four wheels for maximum traction and enhanced stability and ride comfort.

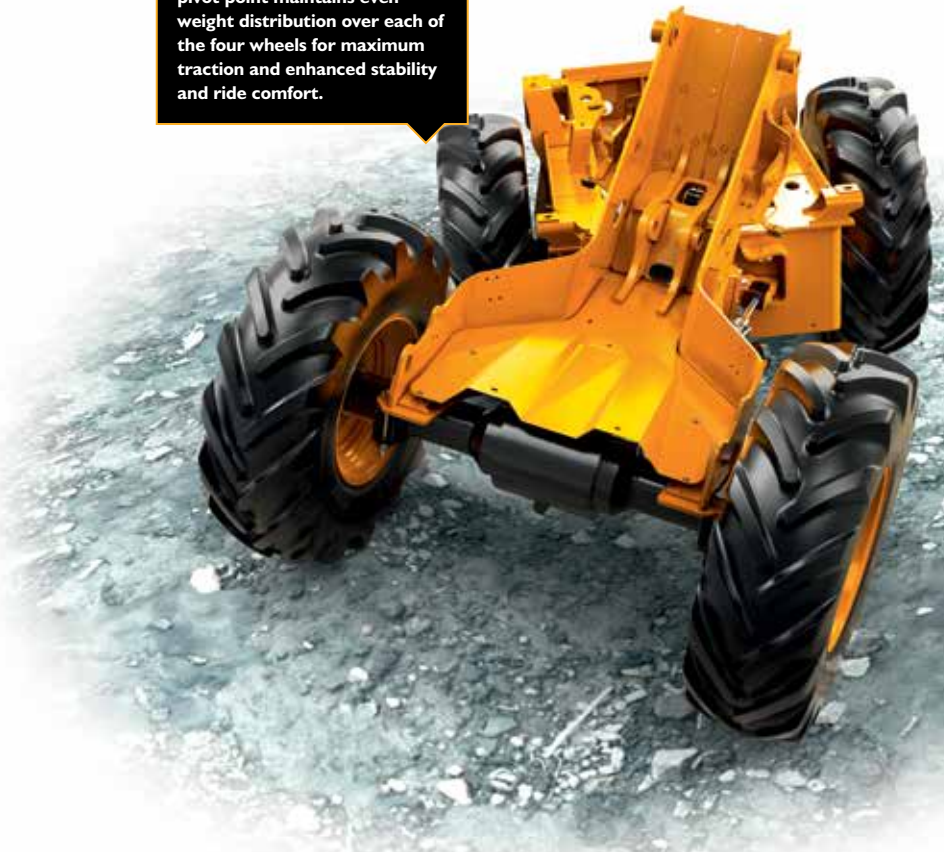

Hydraulics and versatility.

- 4 The ability to change flow rate on the go is perfect for straw spreader or sweeper use, while the second boom auxiliary option accommodates a wide range of twin auxiliary attachments.
- 5 Available LED work light packages include boom and cab-mounted forward options, and a rear-mounted hitch light, for enhanced visibility and productivity at night and in dark operating environments.
- 6 For easier connection to attachments and accurate placement of loads, the JCB TM320 feature side-shift functionality.

- 7 An optional hydraulic rear tow hitch further increases machine versatility. The tow hitch features a fold-up design to prevent impact damage and grounding when working on uneven ground.
- 8 The foot brake features a selectable transmission dump for superb multi-functioning control and increased engine speeds during loading or rehandling.
- 9 The TM320's variable flow auxiliary hydraulics are easy to use and designed to maximize productivity and efficiency. This flow sharing system, with a variable flow piston pump, allows multiple functions to be performed simultaneously.

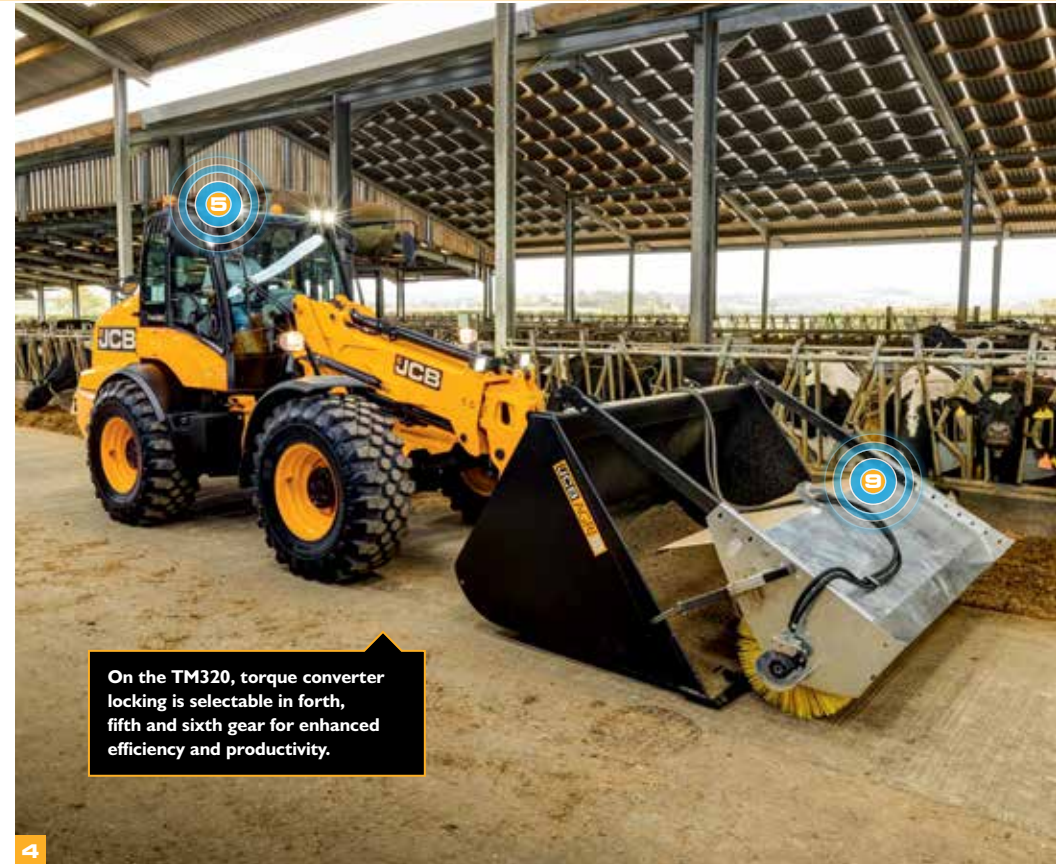

On the TM320, torque converter locking is selectable in forth, fifth and sixth gear for enhanced efficiency and productivity.



IN CONTROL, IN COMFORT.

THE JCB TM320 IS EASY TO OPERATE—THANKS TO ERGONOMIC, INTUITIVE CONTROLS AND INTELLIGENT FEATURES—AND PROVIDE A COMFORTABLE WORKING ENVIRONMENT FOR INCREASED PRODUCTIVITY.

At your command.

- 1 From a high, centrally mounted driving position JCB TM320 operators enjoy the benefit of a low boom pivot point and large glass areas for an unobstructed 360-degree view.
- 2 Constant flow hydraulics are intuitive to use. With an in-cab flow rate display, hydraulics can be adjusted on the go.
- 3 Manual and automatic transmission modes provide the operator with control of transmission performance.

- 4 For fast and precise control, the TM320 are fitted with a fully-proportional, single-lever servo joystick control. Operators can change gears, speed and direction quickly and easily with one ergonomically-designed joystick.
- 5 The HVAC system allows operators to stay comfortable and focused for longer. A 3-speed fan heater is fitted as standard; optional air conditioning makes it even easier to set an ideal cab working temperature, regardless of outside weather conditions.

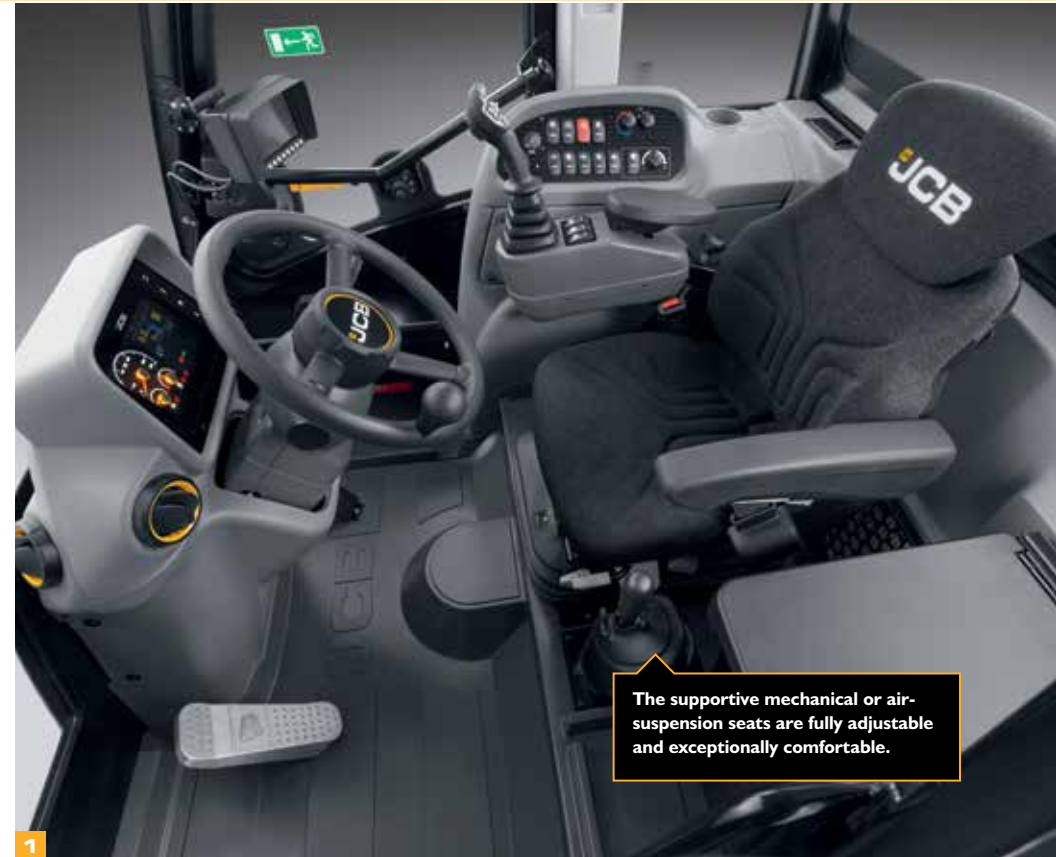

The supportive mechanical or air-suspension seats are fully adjustable and exceptionally comfortable.



Sitting comfortably.

- 6 The cab is large and roomy, with plenty of convenient storage for work essentials and personal property.
- 7 Boom-end damping on lower and extend/retract reduces shock to the operator and the machine itself.
- 8 A color, LED dashboard relays useful operating information including in-cab daily checks, fuel consumption data, diesel exhaust fluid (DEF) levels and hydraulic flow rate.
- 9 Backlit switches ensure quick and accurate control recognition, even in the dark.



6



7

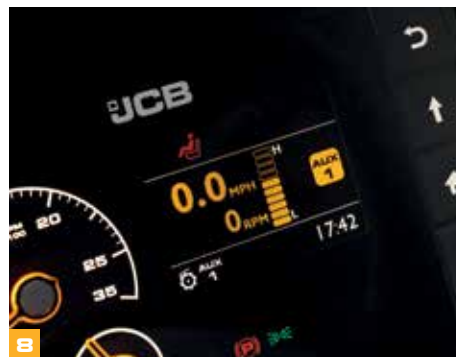

8



9

SERVICING MADE EASY.

THE TM320 IS EASY TO MAINTAIN AND SERVICE, WHICH MEANS LESS DOWNTIME.

Maintenance made easy.

1 The JCB TM320 use a sealed-for-life SCR system, requiring no costly diesel particulate filter (DPF) to comply with Tier 4 Final legislation.

The diesel and DEF (diesel exhaust fluid) tanks, as well as all daily check points, are easily accessible from ground level.

The wide-core, single-faced cooling pack delivers excellent performance. A cyclonic air cleaner reduces debris build-up in the air filter and an air intake scavenge system removes debris, extending service intervals. An automatic reversing fan is available to further simplify the clearing of debris.

2 The TM320's wide-opening rear engine cover provides clear access to service points. Grease points are easily accessible, and no tools are required to access the battery.

3 The TM320's self-lubricating boom wear pads and dry boom lubrication provide virtually maintenance-free operation. The use of graphite-impregnated bronze bushes throughout allows greasing intervals to be extended to 500 hours.



Keeping you safe.

- 4 Access steps are inclined and equally spaced, and well-positioned grab handles provide three points of contact at all times.
- 5 Hose burst check valves on the rams prevent collapse in the event of hose failure.
- 6 The low boom profile and low boom pivot make for superb forward visibility.

- 7 An in-cab, electronic, two-stage quick hitch isolation control protects against accidental release of attachments.
- 8 For real time vehicle tracking, the TM320 are equipped with JCB LiveLink telematics.



A SMART INVESTMENT.

JCB MACHINES ARE RECOGNIZED AROUND THE WORLD FOR LOW OPERATING COSTS AND EXCEPTIONAL RESALE VALUES.



EcoMAX saves you money.

1 Innovative Clean Burn technology allows JCB engines to meet Tier 4 Final regulations without a diesel particulate filter (DPF) and therefore without the productivity and cost impacts of DPF regeneration and DPF replacement. Instead, the JCB engines in the TM320 use a sealed-for-life Selective Catalytic Reduction (SCR) system.

2 The TM320 are equipped with torque converter locking in fourth, fifth and sixth gear for increased speed, quicker journey times and reduced fuel consumption.

Torque converter locking on the transmission provides improved efficiency and fuel economy.



3 By producing high power and torque at engine speeds as low as 1300–1400 RPM, the JCB EcoMAX engine provides fuel-efficient matching of transmission and hydraulics.

4 The 125 hp (93 kW) EcoMAX engine fitted with a variable speed cooling fan or hydraulic reversing fan with manual override that automatically adjusts to ambient temperatures, for optimal fuel efficiency and reduced in-cab noise.

5 High back-off power brakes reduce viscous drag during roading and rehandling, for improved fuel economy.

6 The TM320's load-sensing hydraulics consume power only on demand, to reduce fuel consumption.



3



4



5



6

LIVELINK, WORK SMARTER.

LIVELINK IS AN INNOVATIVE SOFTWARE SYSTEM THAT LETS YOU MANAGE YOUR JCB MACHINES REMOTELY FROM A COMPUTER, TABLET OR SMART PHONE.

Productivity and cost benefits—By providing information like idle time monitoring and machine fuel consumption, JCB Livelink helps reduce your fuel usage, saving money and improving productivity. Machine location information can help improve efficiency and possibly reduce insurance costs.

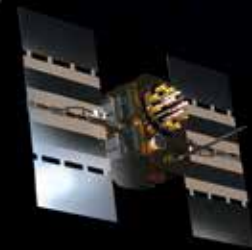

Maintenance benefits—Accurate hours monitoring, maintenance history records, critical machine alerts and service alerts for improved maintenance planning.

Security benefits—Real-time geofencing allows you to set operating zones, while curfew alerts let you know when your machinery is operated outside of predetermined times. Location information helps to plan and monitor the safe storage of your machine.

VALUE ADDED.

WHATEVER YOU NEED AND WHEREVER YOU ARE, JCB'S DEPENDABLE NORTH AMERICAN DEALER NETWORK IS HERE TO MAKE SURE YOUR MACHINERY PERFORMS TO ITS FULL POTENTIAL.



1 JCB Technical Support Service provides instant access to factory expertise, day or night.

JCB's Finance team is always on hand to provide fast, flexible, competitive quotes.



JCB Yellow Shield offers comprehensive extended warranties and service agreements, as well as service-only or repair and maintenance contracts. JCB maintenance teams offer competitive labor rates and no-obligation quotes.



2 The global network of JCB Parts Centers is a model of efficiency. With 16 regional bases, we can deliver around 95 percent of all parts anywhere in the world. Our genuine JCB parts are designed to work in perfect harmony with your machine for optimum performance and productivity.

Note: JCB LIVELINK and JCB ASSETCARE may not be available in your region, so please check with your local dealer.

STATIC DIMENSIONS

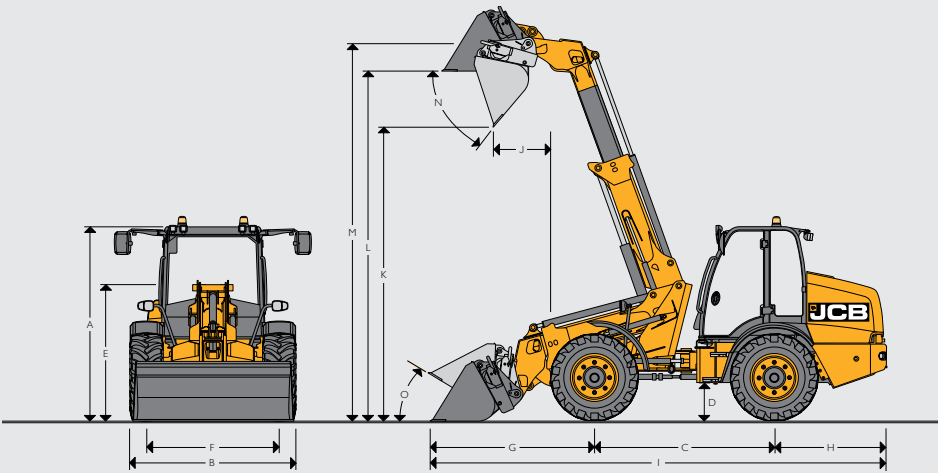

STATIC DIMENSIONS

A	Overall height	ft-in (mm)	8-10 (2,703)
B	Overall width (over tires)	ft-in (mm)	7-9 (2,350)
C	Wheelbase	ft-in (mm)	8-4 (2,550)
D	Ground clearance	ft-in (mm)	1-7 (472)
E	Height to top of boom pivot	ft-in (mm)	6-0 (1,835)
F	Wheel track	ft-in (mm)	6-2 (1,870)
G	Axle to shovel toe plate	ft-in (mm)	5-4 (1,627)
H	Axle to counterweight face	ft-in (mm)	7-0 (2,143)
I	Total length*	ft-in (mm)	20-9 (6,322)
J	Dump reach	ft-in (mm)	3-1 (933)
K	Dump height	ft-in (mm)	14-10 (4,511)
L	Load over height	ft-in (mm)	17-1 (5,200)
M	Pin height	ft-in (mm)	17-7 (5,367)
N	Maximum dump angle	degrees	39
O	Roll back at carry	degrees	41
	Total length to front of hitch	ft-in (mm)	19-4 (5,886)
	Inside radius	ft-in (mm)	6-7 (2,001)
	Outside radius (edge of tire)	ft-in (mm)	14-3 (4,350)
	Outside radius (over shovel)	ft-in (mm)	15-2 (4,633)
	Articulation angle	degrees	±43
	Operating weight	lb (kg)	18,122 (8,220)
	Front axle weight	lb (kg)	6,107 (2,770)
	Rear axle weight	lb (kg)	12,103 (5,490)
	Tyres used for specifications		Michelin XMCL 460/70R24
	Bucket used for specification		1.3 cyd (1.0 m3)
	Hitch used for specification		Qfit

*Please note total length: machine fitted with standard bucket – boom fully down, shovel crowded fully back.

ENGINE

Machine model	TM320		
Manufacturer	JCB		
Model	EcoMAX		
Capacity	ltr	4.4	
Bore	mm	103	
Stroke	mm	132	
Aspiration	Turbocharged/charge cooled		
Number of cylinders	4		
Power rating			
Gross power to SAE J1995/ISO 14396	hp (kW)	125 (93) @ 2,200 RPM	
Net power to J1349/EEC 80/12	hp (kW)	115 (86) @ 2,200 RPM	
Torque rating			
Gross torque	ft lb (Nm)	405 (550) @ 1,500 RPM	

TRANSMISSION

Machine model	TM320		
Type	Powershift		
Make	JCB		
Model	PS760 - 6 Speed		
Max travel speed	mph (kph)	24 (40)	

AXLES

Machine model	TM320		
Type	Epicyclic hub reduction		
Make	JCB		
Overall axle ratio/ drop box ratio	13.71		
Chassis angle oscillation	degrees	±10°	
Maximum travel speed	mph (kph)	24 (40)	

BRAKES

Machine model	TM320		
Service brakes	In board oil immersed brakes		
Parking brake	Cable operated disc brake on transmissions output shaft		

NOISE AND VIBRATION

			Uncertainty	Measurement conditions.
Noise at the operator station	LpA	73 dB	+/- 1 dB	Determined in accordance with the test method defined in ISO 6396 and the dynamic test condition defined on 2000/14/EC.
Noise emission from the machine	LWA	107 dB	+/- 1 dB	Guaranteed equivalent sound power (external noise) determined in accordance with the dynamic test conditions defined in 2000/14/EC.
Whole body vibration	m/s ²	0.39	+/- 0.11 dB	ISO 2631-1:1997 normalized to an 8h reference period and based upon a test cycle comprising of loader work (soil).
Hand arm vibration	m/s ²	<2.5	N/A	ISO 5349 2:2001 dynamic test conditions.

SERVICE FILL CAPACITIES

Machine model	TM320	
Hydraulic tank & transmission	gal (ltr)	25.6 (97)
Fuel tank	gal (ltr)	42.3 (160)
Engine oil sump	gal (ltr)	3.7 (14)
Axle oil (front) including hubs	gal (ltr)	5.3 (20)
Axle oil (rear) including hubs	gal (ltr)	5.3 (20)
Drop box	gal (ltr)	0.3 (1.3)
DEF	gal (ltr)	7.7 (29)

HYDRAULICS

Machine model	TM320	
Pump type	Variable displacement piston pump	
Pump maximum flow	gpm (lpm)	37 (140)
Pump maximum pressure	psi (bar)	3,336 (230)
Hydraulic cycle times		
Boom raise	seconds	5.8
Boom lower	seconds	6.7
Extend	seconds	4.1
Retract	seconds	3.1
Bucket dump	seconds	3.1
Bucket crowd	seconds	3.3
Total cycle time	seconds	26.1

ELECTRICAL SYSTEM

Machine model	TM320	
System voltage	Volt	12
Alternator output	Amp Hour	150
Battery capacity	Amp Hour	120

TIRE OPTIONS

Manufacturer	Size	Type	Applica-tion	Dimensional changes	
				Overall height in (mm)	Width over tyres in (mm)
Michelin	460/70R24	XMCL	Ag	0 (0)	0 (0)
Michelin	500/70R24	XMCL	Ag	0.9 (24)	1.5 (38)
Michelin	460/70R24	BIBLOAD	AG/EM	-0.2 (-4)	0 (0)
Michelin	500/70R24	BIBLOAD	AG/EM	0.7 (19)	2.1 (54)

LOADER PERFORMANCE

Machine model	TM320	
100% straight tipping load	lb (kg)	10,459 (4,744)
100% full turn tipping load	lb (kg)	8,182 (3,711)
80% full turn tipping load	lb (kg)	6,546 (2,969)
60% full turn tipping load	lb (kg)	4,909 (2,226)

Straight and Full Turn Tipping Load with forks @ 24 inch LC and direct mount to Qfit carriage to EN474 (ISO 14397)

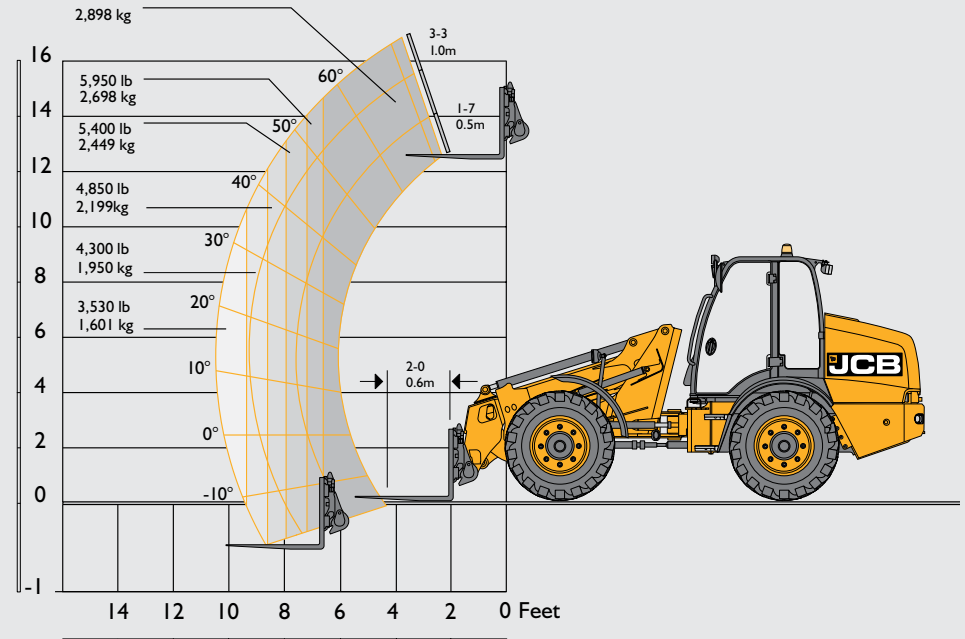

STANDARD/OPTIONAL EQUIPMENT

	TM320
ENGINE AND COOLING	
125 hp JCB engine	•
Cyclonic air filter	•
Air intake scavenge system	•
Widcore cooling pack	•
Auto reversing fan	+
TRANSMISSION / AXLES	
6 speed Powershift transmission	•
Lock-up torque converter in gears 4 - 6	•
24 mph travel speed	•
Transmissions disconnect on footbrake	•
Forward / reverse controls on joystick	•
Column mounted transmission selector	•
In board oil immersed disc brakes	•
Limited slip differentials front	+
HYDRAULICS	
Servo controls	•
Flow sharing hydraulics	•
Proportional boom and auxiliary controls	•
Adjustable constant flow hydraulics	•
Variable displacement piston pump	•
Priority steer valve	•
Hose burst check valves	•
JCB Smoothride system	+

	TM320
CAB	
ROPS/FOPS safety structure	•
Laminated screen	•
Fully adjustable mechanical seat	•
Air suspension seat	+
Interior light	•
Tilt and telescopic steering column	•
Adjustable joystick control console and armrest	•
Front and rear wash / wipe	•
3 speed heater fan	•
Air conditioning	+
RH opening window with lock back	•
LH opening door with door lock back	•
Single lever joystick controls	•
Loader control isolator	•
External rear view mirrors	•
Front and roof screen blinds	•
Additional storage box	+
ELECTRICAL	
Road lights front and rear	•
Reverse lights	•
Battery isolator	•
Direction indicators	•
Twin beacons	+
Front and rear worklights	+
Boom worklights	+
Reverse foglight kit	+
LiveLink telematics	•
12 V in-cab power socket	•

	TM320
CHASSIS AND BODYWORK	
Articulated steering	•
Center pivot oscillation	•
Plastic front and rear fenders	•
Fixed bottom step	•
Full width rear counterweight	•
Recovery hitch	•
Prop shaft guard	•
Deluxe exterior mirrors	•
Hydraulic tow hitch	+
LOADER	
Center mounted single stage telescopic boom	•
Parallel lift	•
End damping on boom lower, extend and retract	•
JCB Q-fit carriage	+
Electrical in cab quickhitch pin isolation	•

STANDARD •
 OPTIONAL +
 NOT AVAILABLE X

NB. Regional variations may apply to standard and optional equipment



ONE COMPANY, OVER 300 MACHINES.

Your nearest JCB dealer



CUSTOMERS FOR LIFE

(844) 432-4724

fairchildequipment.com

9999/5676 en-GB 02/17 Issue 3 (T4F) DWUSA 4639

Articulated Telescopic Handler TM320

Gross power: TM320: 125 hp (93 kW) Lift capacity: 6,390 lb (2,898 kg), Lift height: 17'1" (5,200 mm)

JCB North America

2000 Bamford Blvd., Pooler, Georgia, 31322 Tel: (912) 447-2000

Download the very latest information on this product range at www.jcb.com

JCB inc. All rights reserved. No part of this publication may be reproduced, stored in a retrieval system, or transmitted in any form or by any other means, electronic, mechanical, photocopying or otherwise, without prior permission from JCB inc. All references in this publication to operating weights, sizes, capacities and other performance measurements are provided for guidance only and may vary dependant upon the exact specification of machine. They should not therefore be relied upon in relation to suitability for a particular application. Guidance and advice should always be sought from your JCB Dealer. JCB reserves the right to change specifications without notice. Illustrations and specifications shown may include optional equipment and accessories. The JCB logo is a registered trademark of J C Bamford Excavators Ltd.

 /JCBNA
  /JCBNA
  /JCBNORTHAMERICA

