

# COMBi-PPT

17,300 lbs

HIGH CAPACITY  
POWERED PALLET TRUCK

# COMBiLiFT

LIFTING INNOVATION

Equipped with our patented multi-position tiller arm the Combi-PPT offers safer operation, maximum operator visibility and narrow aisle performance.

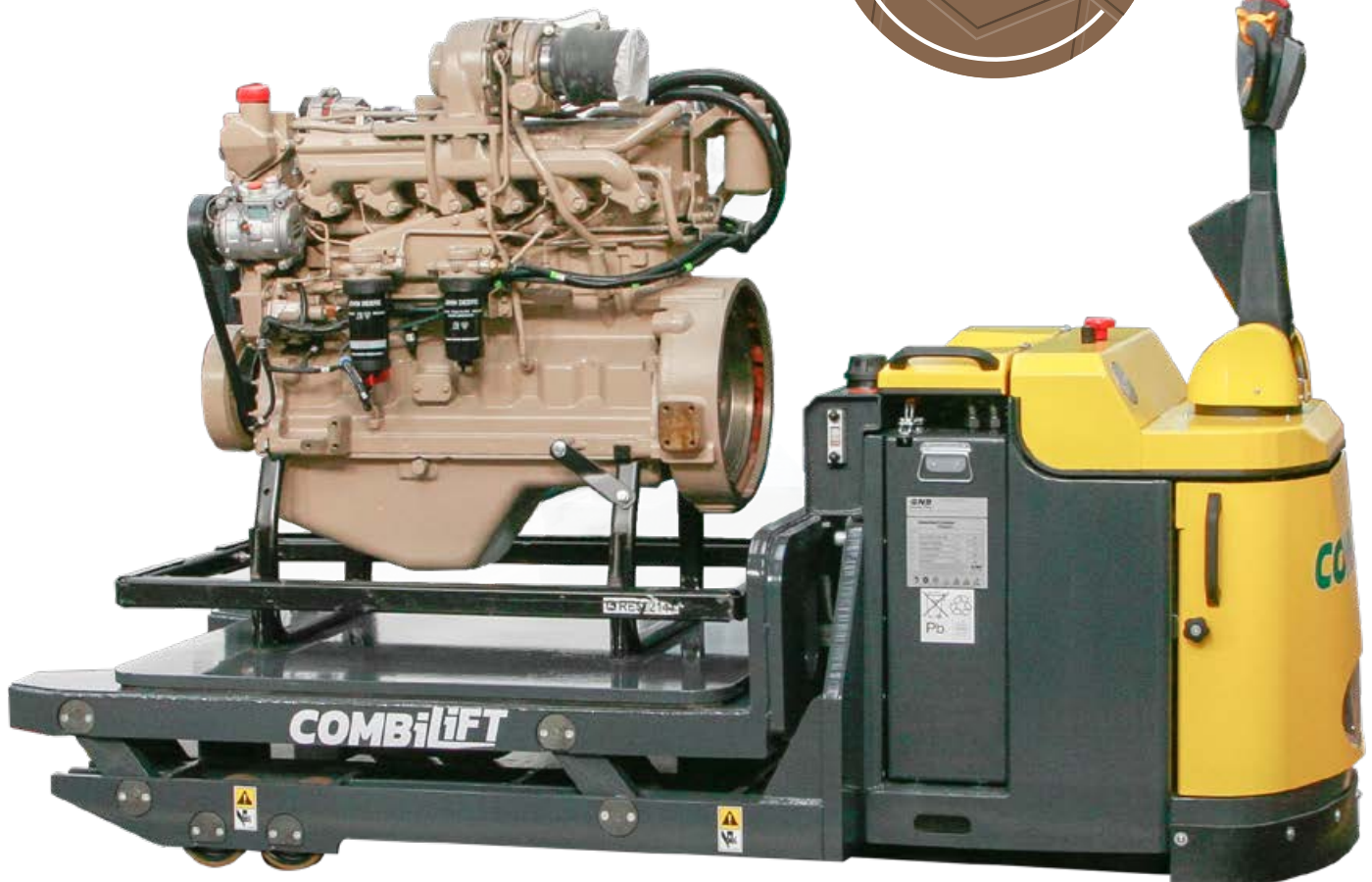

9,000 kg - 16,000 kg available on request



# COMBI-PPT

## 17,300 lbs

### HIGH CAPACITY POWERED PALLET TRUCK

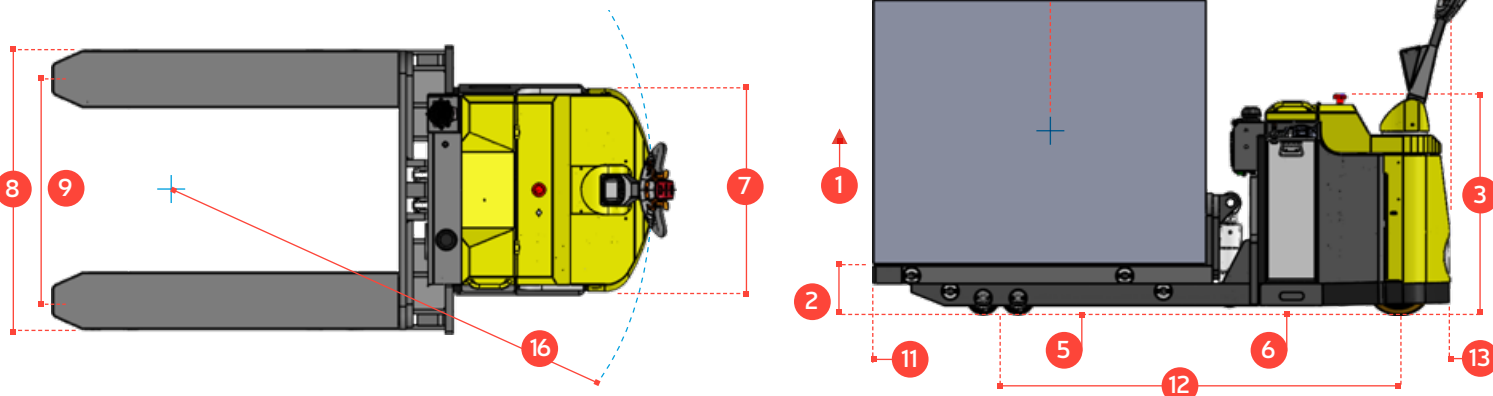

REF.	DESCRIPTION	STANDARD
1	Max. Lift Height	4"
2	Lowered Height	7" (other sizes available)
3	Overall Height	41"
4	Overall Length	96"
5	Ground Clearance Under Fork/Platform	0.8"
6	Ground Clearance to Centre of Wheelbase	0.8"
7	Width	37"
8	Outside Spread of Fork/Platform	24" (other sizes available)
9	Track Front	18"
10	Load Centre Distance	24"
11	Overhang Front	22"
12	Wheelbase	66"
13	Overhang Back	9"
14	Length From Face of Fork/Platform	48"
15	Fork/Platform Length	48" (other sizes available)
16	Minimum Outside Radius	75" mm
A	Capacity	17300 lbs
B	Maximum Ground Speed	6 km/h
C	Gradeability	5%
D	Battery Capacity	24 V / 375 Ah
F	Front Tyre (Polyurethane) x 8	OD 5" / Width 2"
G	Rear Tyre (Vulkollan) x 2	OD 12" / Width 5"
H	Standard Colour	Yellow & Grey
I	AC Electric Traction Motor x 2	24 V / 4 kW
J	AC Electric Pump Motor	24 V / 5 kW
K	Unladen Weight with Battery	5000 lbs

### Superior safety with Combilift's patented Multi-Position Tiller Arm

The tiller can be turned to the left or right to allow the operator to remain at the side. This enables full visibility of the load and forks, while maintaining full steering control, providing greater awareness of the surroundings for enhanced overall safety.

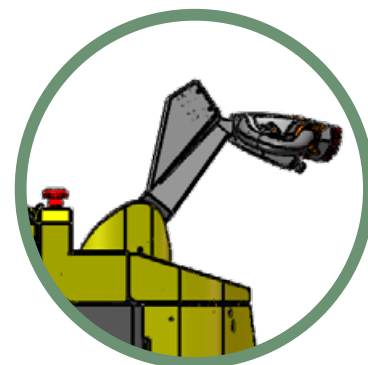

### Features Include:

- Power Steering
- AC Motor Technology
- Dual Rear Wheel Drive
- Patented Multi-Position Tiller Arm
- Tiller Mounted Monitor

European Patent No.2892841; US Patent No. 9586797

### Without Patented Tiller Arm

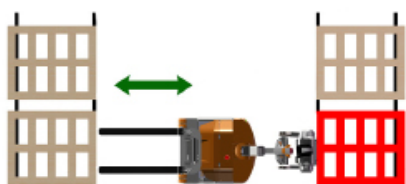

### Using Combi-PPT with Patented Tiller Arm



Standing to the side of the truck eliminates the risk of being trapped or crushed while allowing the Combi - PPT to operate in very narrow aisles.

### Optional Extras:

- Alternative Fork/Platform Configurations
- Camera
- Auxiliary Hydraulics
- Ride-on Platform

COMBILIFT HAS A POLICY OF CONTINUOUS PRODUCT DEVELOPMENT AND RESERVES THE RIGHT TO ALTER SPECIFICATIONS WITHOUT PRIOR NOTICE. SPECIFICATIONS AND/OR DIMENSIONS MAY VARY FROM THOSE ILLUSTRATED IN SOME COUNTRIES.