



**STRONG PARTNERS.
TOUGH TRUCKS.™**



AP20Z SERIES

HYSTER ASCENDER™ AERIAL WORK PLATFORM

WWW.HYSTER.COM

HYSTER ASCENDER™ AERIAL WORK PLATFORM

From ladders to movable staircases, the task of getting workers up and down just got easier. The new Hyster ASCENDER™ aerial work platform (AWP) can do it all, even more efficiently. Whether the job is stock picking, facility maintenance or retail display and signage, the Hyster ASCENDER™ AWP has the small footprint, speed and versatile features to get in position and get the job done quickly and easily with little disruption to your workflow.

The Hyster ASCENDER™ AWP has a 450 lb. capacity and 19.5 foot lift height and is the ideal tool for a range of applications from manufacturing to retail. And with the benefit of Hyster superior engineering and advanced technology, it has the robust design and ergonomic features to help reduce downtime and enhance productivity.

Aerial work platforms have a variety of uses:

- Warehousing
- Transporting Materials and Supplies
- Inventory Maintenance
- Distribution
- Stock Picking
- Restocking
- Facility Maintenance
- Retail Displays
- Rental Market





> **ADVANCED DEPENDABILITY**

TOUGH ELECTRONICS

The CANbus control system enhances reliability and dependability.

- Allows digital communication exchange between subsystems
- Substantial reduction in connections and wiring complexity
- Communications over two-wire CANbus reduces wiring
- Extensive monitoring capability without additional cost
- Fast data rate allows real-time control
- Access to all control parameters possible via single port

Also, dual AC motors provide traction and steering, eliminating hydraulic steering and linkage with a “zero-turn steering” effect. And the sealed Absorbed Glass Mat (AGM) deep-cycle batteries provide a maintenance-free power source.

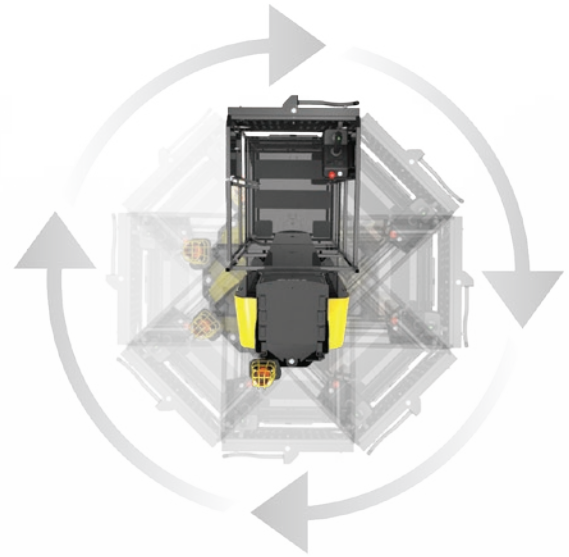

Zero turn radius effect

DURABLE FRAME

The main frame is built from welded A-36 structural-quality steel, and all ballast (including batteries) is integrated into the frame instead of added externally.

- Rugged, durable construction for long service life
- Low center of gravity for stability and operator comfort
- Improved service access to functional components
- All frames are supported by a lifetime, unlimited-hours warranty

100% STEEL MAST

The AWP mast uses heavy duty chains and a robust sheave and bracket design for reliable operation. The mast is constructed of high-strength, low-alloy steel that makes a very stiff and strong structure.

- Lower maintenance and longer service intervals
- Stiffer than aluminum masts for stability and comfort
- Common parts with our order selector products



i³ TECHNOLOGY™

Hyster i³ Technology™ integrates commonality among Hyster® warehouse products and simplifies the way in which operators and technicians alike handle and service the lift. The integrated intelligent interface ties together functionality, software, diagnostic codes, similar interfaces, and is Hyster Tracker compatible.



STREAMLINE OPERATIONS. SIMPLIFY MAINTENANCE.

The Hyster ASCENDER™ AWP can help you save money by streamlining labor costs and removing bottlenecks from blocked aisles. With its versatility and small footprint, the AWP eliminates the need for ladders and movable stairs.

As always, Hyster supports every sale with a highly competitive warranty. With the purchase of a Hyster ASCENDER™ AWP, you will enjoy a 12-month/unlimited-hours, full product warranty, a 3-year/6,000-hour powertrain warranty and a lifetime frame warranty. You can also take advantage of our extensive Parts Distribution and Dealer networks for everyday low pricing of parts and dealer price guarantees.



One of two diagnostic ports

SERVICE IS A SNAP.

The AWP is also easy to service and maintain with an overall simplified design and unrestricted service access to all major components and systems. All of which means more uptime and productivity for you.

- Easy access to control compartment
 - Doors are easy to open and fully removable
 - Allows full access to control panels, hydraulics and mast lift cylinder
- Low maintenance DC brushless hoist motor
- Sealed AGM deep-cycle batteries are maintenance-free
- Easy-access lube fittings
- Cylinder can be removed from mast without removing mast or turning lift on side
- CANbus diagnostic ports are located in the rear compartment and in the operator compartment for easy access

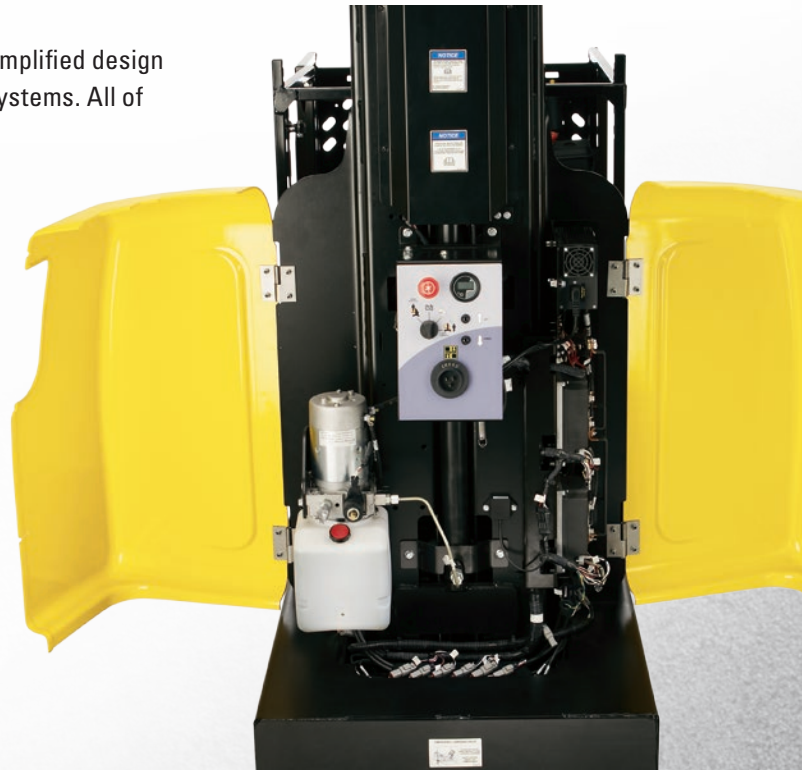

SUPPORTING CUSTOMERS WITH WORLD-CLASS PARTS & SERVICE

Four Parts Distribution Centers strategically located around the world provide a full range of original equipment and aftermarket parts that help maintain our customers' uptime. In fact, our Guaranteed Availability Program ensures that parts that are normally required in the first 2 years of operation will be available from your Hyster® parts dealer within 24 hours or they are free.* We also take that commitment into the field with the Hyster CERTECH® Certification training program. This technical training program provides both systems level as well as product-specific education to ensure products are repaired right the first time.

** Contact your local dealer for program details.*

> EXCEPTIONAL ERGONOMICS

The operator compartment of the Hyster ASCENDER™ AWP is designed with comfort and productivity in mind. The spacious compartment features an anti-slip surface and plenty of storage space for an uncluttered work area. A conventional entry door includes a spring-loaded latch with a proximity sensor that prohibits operation unless the door is in the proper operating position.

The compartment is designed with a low step-in height for ease of entry, and its safety railing is forged from structural-grade steel tubing, creating a secure platform. If personal fall protection is required, two harness attachment points are provided.

AMPLE POWER

The AWP comes standard with sealed, maintenance-free, 225-amp/hour-rated AGM batteries. The four 6-volt batteries for the 24-volt operating system provide large storage capacity for long run times. The charge port and cord retainer are easy to access and come equipped with a handy 10-foot charge cord.



Upper controls with multifunction control handle

MULTIFUNCTION CONTROL HANDLE

The multifunction control handle features a comfortable grip and proportional control. It seamlessly controls traction, steering, lift and lower functions and includes a horn button and an operator interlock switch.



Lower control panel

UPPER CONTROL PANEL

The upper control panel houses the multifunction control handle and all other controls. These include a display for Battery Discharge Indicator (BDI) and status codes, a selector switch for lift/lower and traction/steering functions, a selector switch for traction speed in the lowered position, and a battery disconnect switch for shutdown.

LOWER CONTROL PANEL

Accessible at the rear service doors, the lower control panel includes a rotary switch that provides mode selection and security, a display providing BDI and status codes, and momentary switches for lift and lower. A battery disconnect switch and a battery charger convenience port are also included.



Ladders and movable stairs are difficult to position and challenging to use. The Hyster ASCENDER™ AWP solves both problems with one versatile tool. The AWP offers the maneuverability to place workers precisely where you need them. The AWP can turn a precarious two-man job into an efficient one-man job, saving time and enhancing productivity.

TRACTION DRIVE AND STEERING

The powerful drive system will put the AWP where you need it quickly and efficiently. Fully proportional speed control is driven by two efficient AC motors and the multifunction control handle provides simultaneous drive and steer operation. The steering system is a zero-turn, return-to-center design that's ideal for operation in tight spaces. This intuitive, easy-to-learn system increases operator comfort and productivity.

SMOOTH AND PRECISE HYDRAULICS

The sophisticated hydraulic lift system on the AWP includes an integrated hydraulic power unit and mast lift cylinder. Control is delivered by a combination lift-traction controller. The result is fine control that allows for precise location of the operator compartment. And fully proportional lifting and lowering with soft starts and stops offer enhanced operator comfort and confidence on the job.

INTERLOCK SYSTEMS

The AWP offers multiple interlock features:

- **Operator presence switch** – Prohibits lift, lower or traction control functions unless the switch is engaged
- **Mast elevated sensor** – Reduces travel speed and activates tilt sensor as operator compartment elevates
- **Mode selector switch** – Ensures use of two hands to operate the lower control panel, helping to keep hands away from moving components
- **Tilt sensor** – Prevents lift and drive operations when the AWP is on a surface that is beyond the manufacturer's recommended incline
- **Object tray sensor** – Prevents the operator from lowering onto an object temporarily placed on the tray underneath the platform
- **Object sensing system (Premium Package)** – The object sensing system augments the operator's awareness of moving objects in the area around the AWP. Although not an impact avoidance system, it can help to reduce the potential for unwanted encounters with objects when lowering the operator compartment. When a moving object is detected, the response can include: setting off an audible alarm, inhibiting the lowering function and blinking a red light on the display.

> AP20Z DIMENSIONS

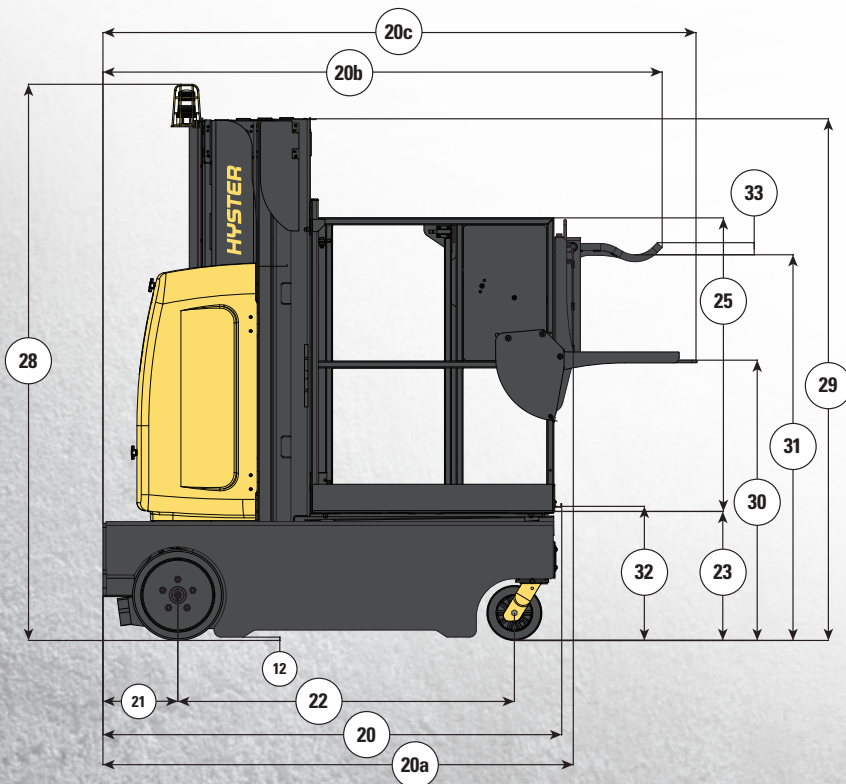
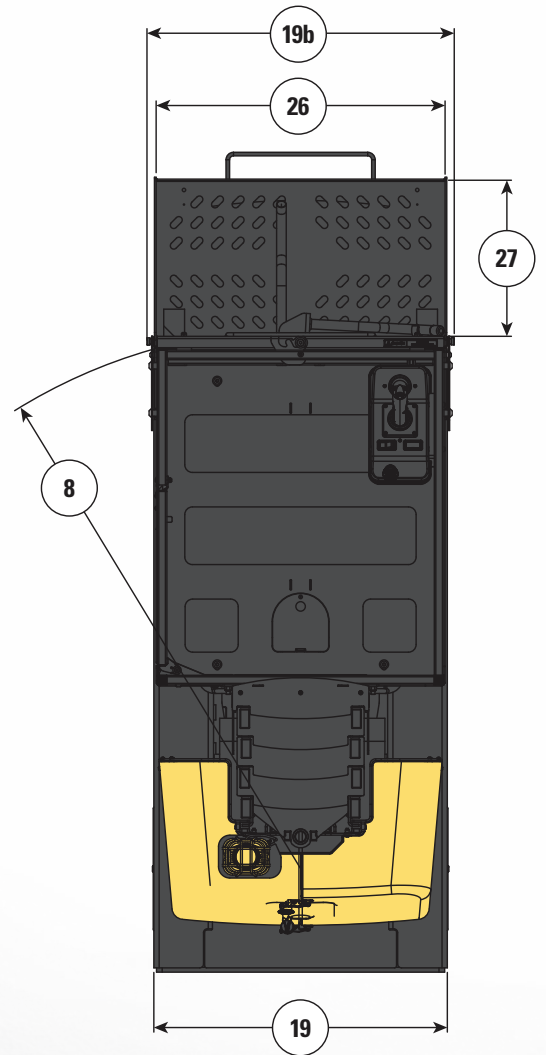
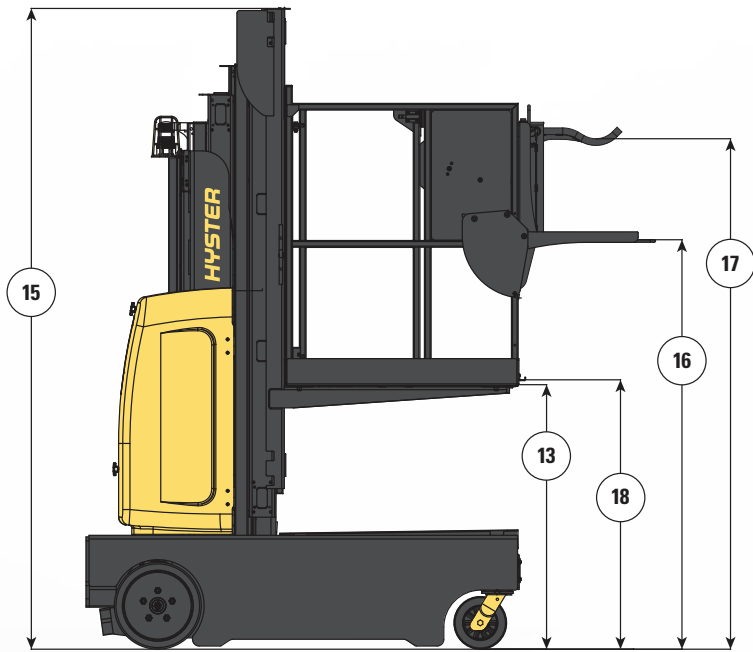



GENERAL	1	Manufacturer		Hyster	
	2	Model Designation		AP20Z	
	3	Power	volts	24	
	4	Operator Type		Pedestrian	
	5	Total Capacity (Operator and Materials)	lb (kg)	450 (992)	
	6	Load Tray Capacity	lb (kg)	150 (330)	
DIMENSIONS	7	Turning Radius Inside	in (mm)	0	
	8	Turning Radius Outside*	in (mm)	56.1 (1425)	
	9	Gradeability - Driving on Slope	%	20	
	10	Grade Clearance	%	6	
	11	Ground Clearance - Center	in (mm)	1.5 (37)	
	12	Ground Clearance	in (mm)	0.5 (12)	
	13	Platform Height	in (mm)	234 (5951)	
	14	Working Height	in (mm)	306 (7781)	
	15	Extended Height	in (mm)	290 (7380)	
	16	Max Tray Height	in (mm)	256 (6504)	
	17	Max Hook Height	in (mm)	271 (6885)	
	18	Max Sign Rack Height	in (mm)	235 (5970)	
	19	Frame Width	in (mm)	30.5 (774)	
	19b	Frame Width, with tray hardware (tray can be removed)	in (mm)	31.9 (810)	
	20	Frame Length	in (mm)	65.7 (1669)	
	20a	Frame Length, tray and object lifting hook both raised and in stowed position	in (mm)	67.5 (1714)	
	20b	Frame Length, tray raised and stowed, with object lifting hook extended for use	in (mm)	80.1 (2034)	
	20c	Frame Length, tray in lowered position for use	in (mm)	85.1 (2162)	
	21	Bumper to drive axle	in (mm)	10.7 (272)	
	22	Wheel base (minimum)	in (mm)	48.2 (1224)	
	23	Step In Height	in (mm)	18.5 (469)	
	24	Platform Size - Width X Length	in (mm)	29.75 x 34.75 (756 x 883)	
	25	Operator Basket Height	in (mm)	42.1 (1068)	
	26	Load Tray Size - Width	in (mm)	30 (762)	
	27	Load Tray Size - Depth	in (mm)	17.2 (437)	
	28	Height - Lowered - Top of Strobe	in (mm)	79.6 (2023)	
	29	Height - Lowered - Top of Mast	in (mm)	74.7 (1898)	
	30	Tray Height (Lowest)	in (mm)	41.3 (1050)	
	31	Hook Height (Lowest)	in (mm)	55.3 (1404)	
	32	Sign Rack (Lowest)	in (mm)	19.2 (488)	
	33	Hook Offset	in (mm)	1.7 (44)	
	PERF.	34	Travel Speed - Lowered / Raised	mph (kph)	3.5 / 0.5 (5.6 / 0.8)
		35	Lift Speed - Empty / Loaded	fpm (m/s)	60 / 45 (0.31 / 0.23)
36		Lowering Speed - Empty / Loaded		30 / 40 (0.15 / 0.20)	
37		Number of Speeds		Infinitely Variable	
WT.	38	Vehicle Weight with Battery	lb (kg)	3438 (1559)	
TIRES	39	Service Brakes		Regen	
	40	Parking Brake - Dual		Spring Apply/Elec. Released	
	41	Drive Wheel - Dia. X Width (in) & Material (2X)		13 x 3.5 Poly - Non Marking	
	42	Guide Wheel - Dia. X Width (in) & Material (2X)		8 x 2 Poly - Non Marking	
PWTRN	43	Battery Type		Lead Acid	
	44	Standard Batteries		4 x 6 Volt 225 Ah AGM	
	45	Charger	amps	20	

* Turning Radius

- Add 2.6 inches (66 mm) for tray and object lifting hook in stowed position
- Add 13.3 inches (338 mm) for object lifting hook extended
- Add 18.6 inches (473 mm) for tray in lowered position

> AT-A-GLANCE FEATURES

STANDARD PACKAGE (PART NUMBER: 4156287)

- 24-volt AC traction controlled electrical system
- 20-amp 110-volt on-board high frequency smart charger
- AGM - maintenance free
- Heavy duty dual drive AC drive units
- Automatic electro-mechanical park brake
- Steering - caster front / dual drive rear
- ADS (Auto Deceleration System) w/regenerative braking
- Heavy duty lift pump and single hydraulic lift cylinder
- 29.75" wide x 34.75" deep operator platform with anti-slip surface
- Mid-mount fold down stockpicker tray with integrated clothes rack
- Signage carrier
- Passive pothole protection system
- Object tray sensor under basket
- Side-entry operator compartment
- Object lifting hook (capacity 40lbs.)
- Tilt alarm
- Amber LED strobe with metal guard (all motion operation)
- Audible alarm (all motion operation)
- Multifunction control handle with ergonomic grip
 - lift/lower/traction interlocks, horn, and variable speed lift control
- Key switch at vehicle base
- Dual power disconnect
- Dual multifunction display with hour meter
 - includes battery state of charge, low battery lift interrupt, fault indicator
- Fork pockets (front access)
- Integral transportation tie-downs
- Lanyard attachment points
- UL classification E
- ANSI, OSHA, and CSA compliant
- Warranty:
 - 12 months / unlimited hour manufacturer's warranty
 - 36 months / 6,000 hour powertrain warranty
 - lifetime frame warranty



PREMIUM PACKAGE (PART NUMBER: 4156288)

- Standard Package plus
- Object alarm: object sensing performance

OPTIONAL EQUIPMENT

Hyster Tracker

INNOVATIVE PRODUCTS ENGINEERED TO MEET THE MOST DEMANDING APPLICATIONS

For more than 80 years, Hyster has been conquering the world's most demanding applications. In the 1920's Hyster started as a manufacturer of lifting machines used in the rigorous logging industry of the United States' Pacific Northwest. A few years later the first forklift trucks were invented and the Hyster brand quickly gained its reputation for rugged quality. Hyster® products are designed to lower your cost of operations. Every product we make — gasoline, LPG, diesel and electric — is purpose-built to excel in its application. Every product is also backed by an unmatched network of specialists.



Dealer Network — Our Dealer Network can offer the expertise of fleet managers, parts suppliers, capital procurement specialists and trainers. Hyster's carefully chosen dealers fully understand customer applications, assist in selecting the right product and provide fast, reliable support.



Hyster Fleet Services — Even if you operate other brands, we can manage your maintenance and replacement plan. We can offer complete fleet analysis, fleet history summary and a cost-effective proposal for replacement and scheduled maintenance.



Parts — With genuine Hyster® replacement parts and UNISOURCE™ parts for all makes of products, we are your one-stop source for parts. In fact, we offer more than 7 million part number crosses for most brands of materials handling and other in-plant mobile equipment.



Rental Products — When leasing or buying isn't a practical option, we have access to more than 14,000 units for short- and long-term rental. We'll help you maintain output in a cost-effective manner.



Hyster Capital — We can arrange solutions for special financing requirements, taking the difficulties out of buying the equipment you need. Whether you purchase or lease a new or used aerial work platform, Hyster Capital offers superior service and competitive rates.



Special Products Engineering Department (SPED) — Different materials require different handling. That's why we can work with you to customize your product. From strobe lights to specially made forks, SPED has the tools to help you get the job done right.



Operator Training — Proper education in operating aerial work platforms minimizes the risk of injuries due to accidents while increasing productivity. Hyster offers OSHA-compliant materials that support the training of qualified operators.



Service — Your local Hyster® dealer offers a flexible, customized and comprehensive maintenance plan based on each product's operation environment. Hyster service programs offer scheduled inspections and maintenance, along with quick, responsive service dispatched to your location.



Hyster Company
P.O. Box 7006
Greenville, North Carolina
27835-7006
Part No. AP20Z/B
2/2016 Litho in U.S.A.

Visit us online at www.hyster.com or call us at **1-800-HYSTER-1**.

Hyster, and  are registered trademarks in the United States and certain other jurisdictions. Hyster products are subject to change without notice.

All products shown with optional equipment. © 2016 Hyster Company. All rights reserved.